

# Large and Small (Far and Near) Liquid Argon Detectors for Accelerator Neutrino Beams

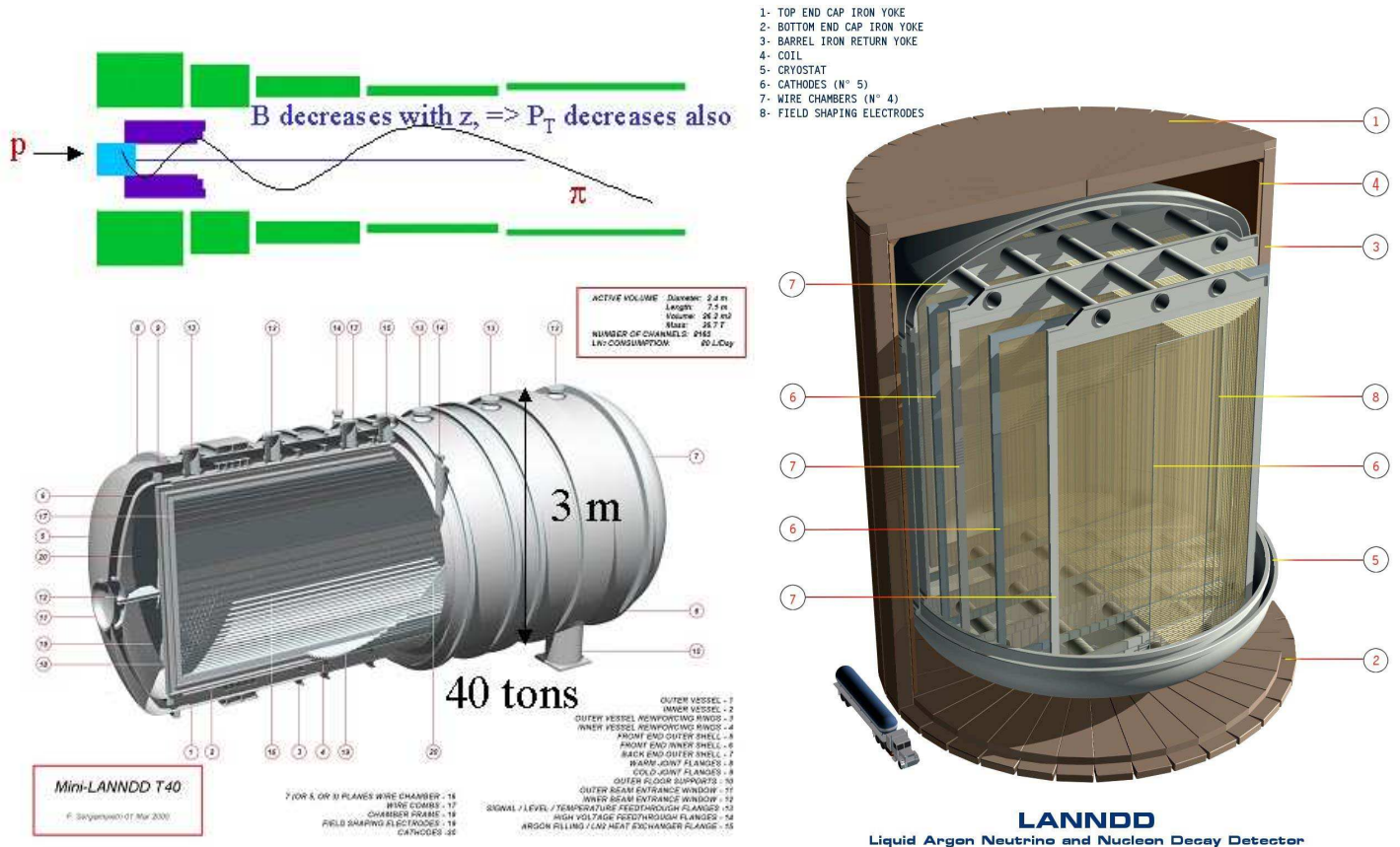

Kirk T. McDonald

Princeton U.

kirkmcd@princeton.edu

NuINT'02

UC Irvine, December 15, 2002

<http://puhep1.princeton.edu/~mcdonald/nufact/>

## Post-Nobel Opportunities

**Data** from atmospheric and solar neutrino experiments  
 $\Rightarrow$  Rich follow-up physics at accelerators and reactors.

Parameter	Atmos.	Solar	Accel.	Reactor	$\beta$ Decay
$ \Delta M_{23}^2 $	ID		<i>PM</i>		
$\theta_{23}$	ID		<i>PM</i>		
$ \Delta M_{12}^2 $		ID	<i>PM</i>	<i>PM</i>	
$\text{Sign}(\Delta M_{12}^2)$		ID = PM			
$\theta_{12}$		ID	<i>PM</i>	<i>PM</i>	
$\nu_{\text{sterile}}$			<i>ID, PM</i>		
$\text{Sign}(\Delta M_{23}^2)$			<i>ID = PM</i>	<i>ID = PM</i>	
$\theta_{13}$			<i>ID, PM</i>	<i>ID</i>	
$\Delta_{CP}$			<i>ID, PM</i>		
$M_\nu$					<i>ID</i>

(ID = Initial Discovery, PM = Precision Measurement)

No evidence for proton decay, “theories” apparently not falsifiable,  
 $\Rightarrow$  Linkage with neutrino expts. should be driven by the latter.

## Visions of Grandeur

If CP violation is measurable in the neutrino sector, it will require a very substantial effort.

Three grand visions (each on 3 continents  $\Rightarrow$  9 giant expts.):

1. 1-4 MW Superbeams ( $\nu_\mu$  from  $\pi$  decay) + 0.1-1 Mton detectors [limited to  $\sin^2 2\theta_{23} \gtrsim 0.005$  by  $\nu_e$  in beam] (\$0.5-1.5B).
2.  $\beta$  beams ( $\bar{\nu}_e$  from  ${}^6\text{He}$ ,  $\nu_e$  from  ${}^{19}\text{Ne}$ ) + 1-Mton detectors (\$1.5B).
3. Neutrino factory ( $\mu \rightarrow \nu_\mu \bar{\nu}_e e$ ) + 0.1-1 Mton detectors (\$2-3B).

Physics case: Must first determine if  $\sin^2 2\theta_{13}$  is large enough to justify expense of a grand effort to measure  $\delta_C$ .

Budget reality: Implementation of these grand visions will require sacrifice of smaller efforts.

$\Rightarrow$  Need success of near-term, mid-sized efforts before launch a big experiment.

Corollary: A megaton proton-decay expt. should be deferred until the linked path to a large accelerator-based neutrino expt. is clear.

## Multimegawatt Sources

Rate  $\propto$  (neutrino flux) (detector mass).

Cost optimization  $\Rightarrow$  Source cost  $\approx$  Detector cost.

Cost of 4 MW proton source for neutrino beams is less than cost of a 1 Mton neutrino detector.

$\Rightarrow$  Strong interest in developing 4-MW proton sources for neutrino beams (+ neutron spallation, accelerator production of tritium, accelerator transmutation of radioactive waste, ...)

But, solid targets not viable at 4-MW due to beam heating, thermal shock and radiation damage,

$\Rightarrow$  Free liquid jet target may be the most appropriate.

BNL E-951 is presently exploring feasibility of mercury jet targets (+ other backup options).

## Studies of Proton Beam + Mercury Jet

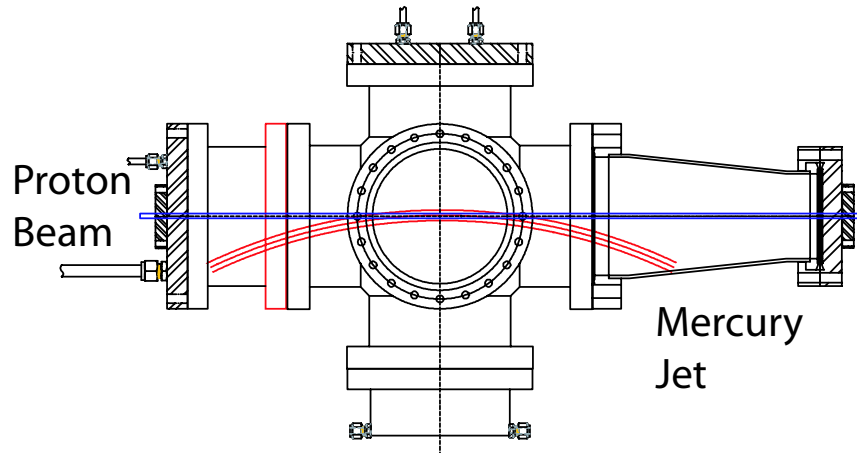

1-cm-diameter Hg jet in  $2e12$  protons at  $t = 0, 0.75, 2, 7, 18$  ms.

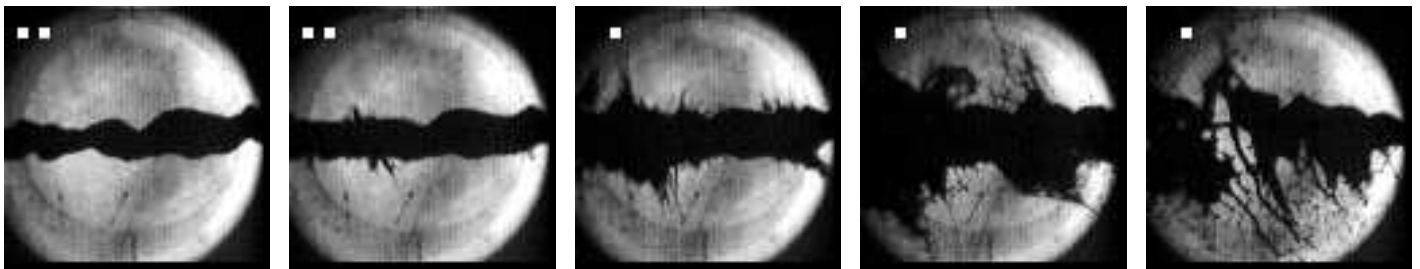

$$\text{Model: } v_{\text{dispersal}} = \frac{\Delta r}{\Delta t} = \frac{r\alpha\Delta T}{r/v_{\text{sound}}} = \frac{\alpha U}{C} v_{\text{sound}} \approx 50 \text{ m/s}$$

for  $U \approx 100 \text{ J/g}$ .

Data:  $v_{\text{dispersal}} \approx 10 \text{ m/s}$  for  $U \approx 25 \text{ J/g}$ .

$v_{\text{dispersal}}$  appears to scale with proton intensity.

The dispersal is not destructive.

Next step: Mercury jet in beam inside 15-T magnetic field.

## The Neutrino Horn Issue

- 4 MW proton beams are achieved in BNL, CERN and FNAL scenarios via high rep rates:  $\approx 10^6/\text{day}$ .
- Classic neutrino horns based on high currents in conductors that intercept much of the secondary pions will have lifetimes of only a few days in this environment.
- Consider instead a solenoid horn with conductors at larger radii than the pions of interest (*c.f.*, Neutrino Factory Design).
- Adiabatic reduction of the solenoid field along the axis,  
 $\Rightarrow$  Adiabatic reduction of pion transverse momentum,  
 $\Rightarrow$  Focusing.

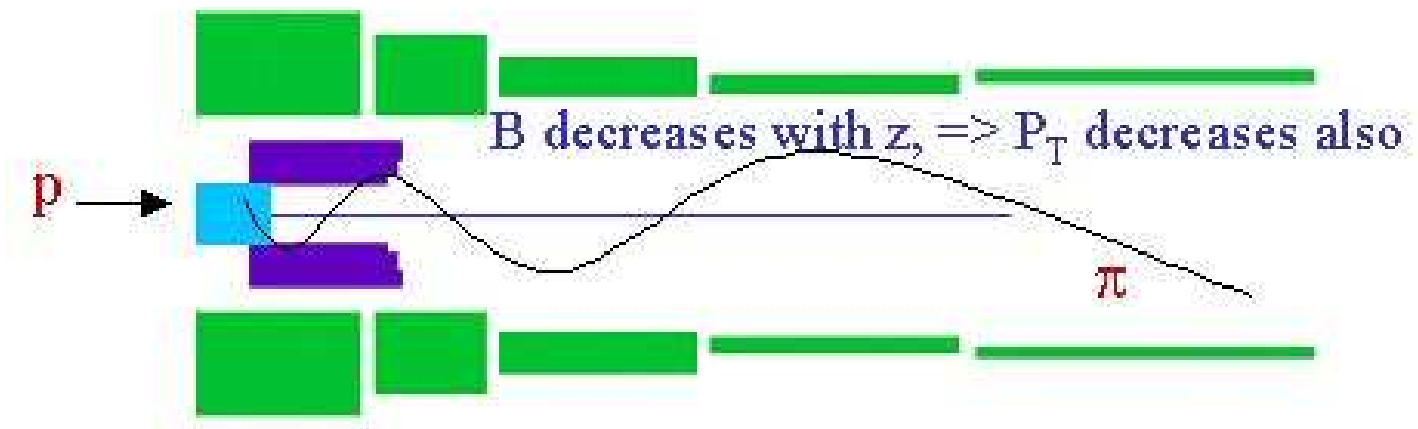

- No sign selection in horn,  $\Rightarrow$  Both  $\nu_u$  and  $\bar{\nu}_m u$ ,  $\Rightarrow$  Detector must measure sign of final-state  $\mu$  or  $e$ .

See, <http://pubweb.bnl.gov/users/kahn/www/talks/Homestake.pdf>

## Liquid Argon the Best Detector to Study $\sin^2 2\theta_{23}$ in the NUMI Beamline

- $\approx 10$  times better per kton than water Čerenkov for  $\nu_\mu \rightarrow \nu_e$  appearance at 1-2 GeV (Harris).

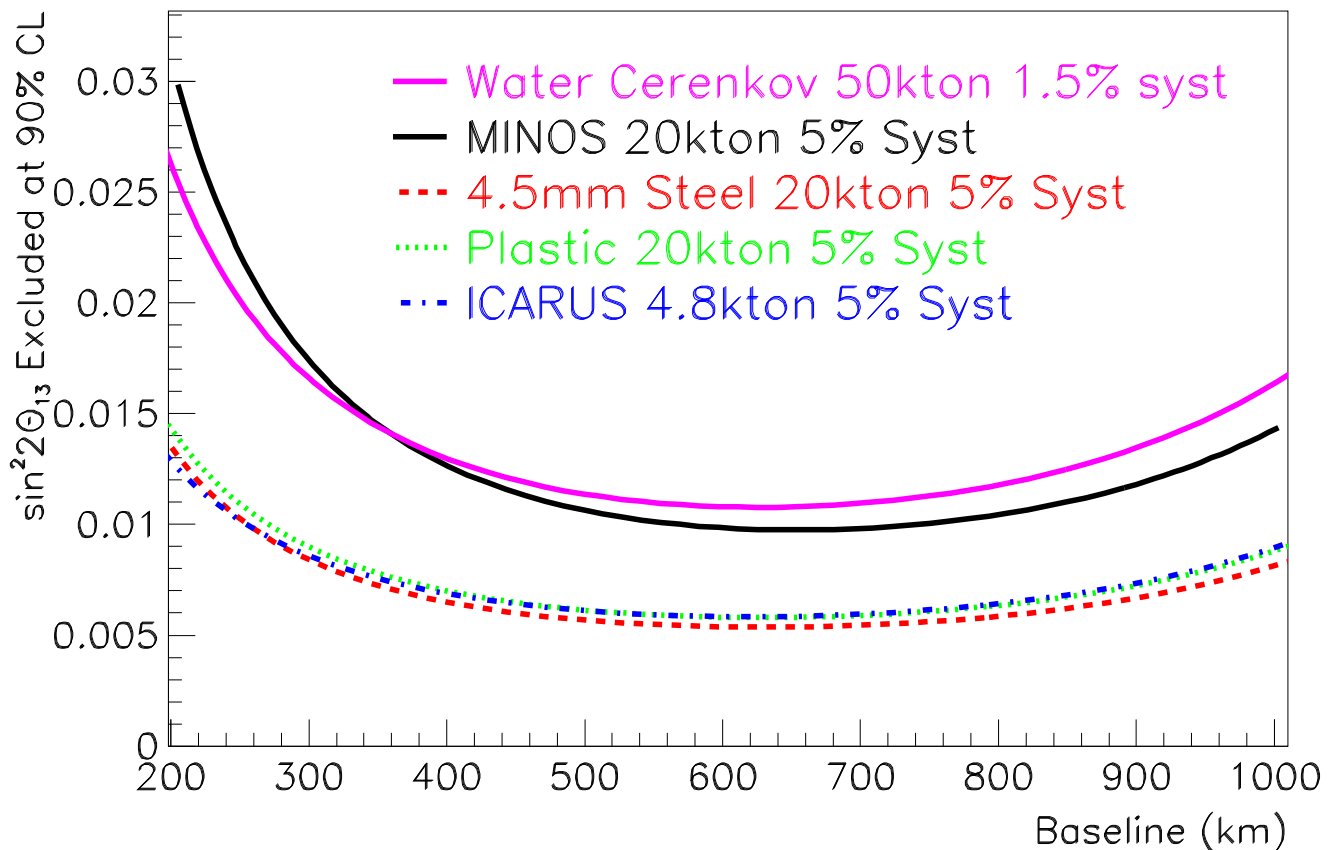

- Density = 1.4;  $X_0 = 14$  cm; can drift electrons 2-4 m.
- 100% sampling tracking and calorimetry.
- Construction is simplest of large neutrino detector options.
- Best rejection of neutral current backgrounds, including soft  $\pi^0$ 's.

# ICARUS – a Working Liquid Argon Detector

<http://www.aquila.infn.it/icarus/>

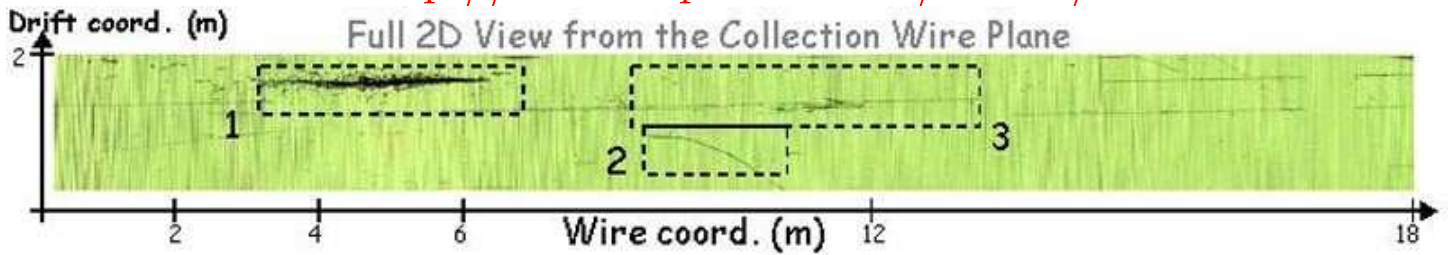

## Zoom details

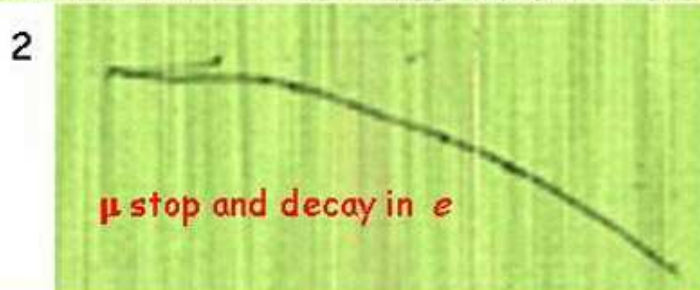
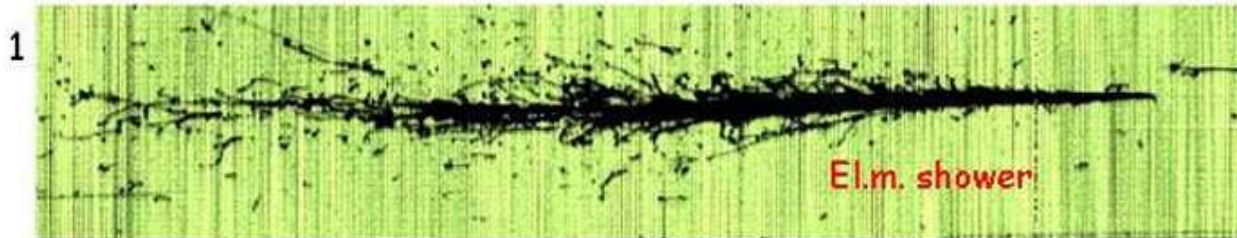

Induction I

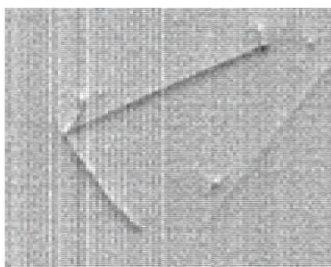

Induction II

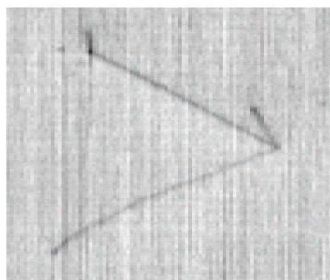

Collection

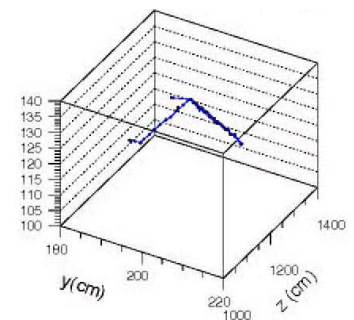
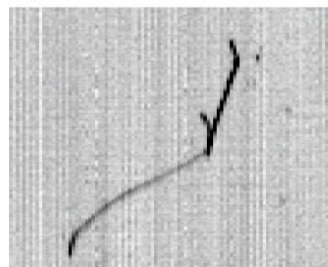

- Operates at the Earth's surface with near zero overlap of cosmic ray events.
- Operates with deadtimeless, selftriggering electronics.

# LANNDD – 100 kton Liquid Argon Neutrino and Nucleon Decay Detector

- 1- TOP END CAP IRON YOKE
- 2- BOTTOM END CAP IRON YOKE
- 3- BARREL IRON RETURN YOKE
- 4- COIL
- 5- CRYOSTAT
- 6- CATHODES (N° 5)
- 7- WIRE CHAMBERS (N° 4)
- 8- FIELD SHAPING ELECTRODES

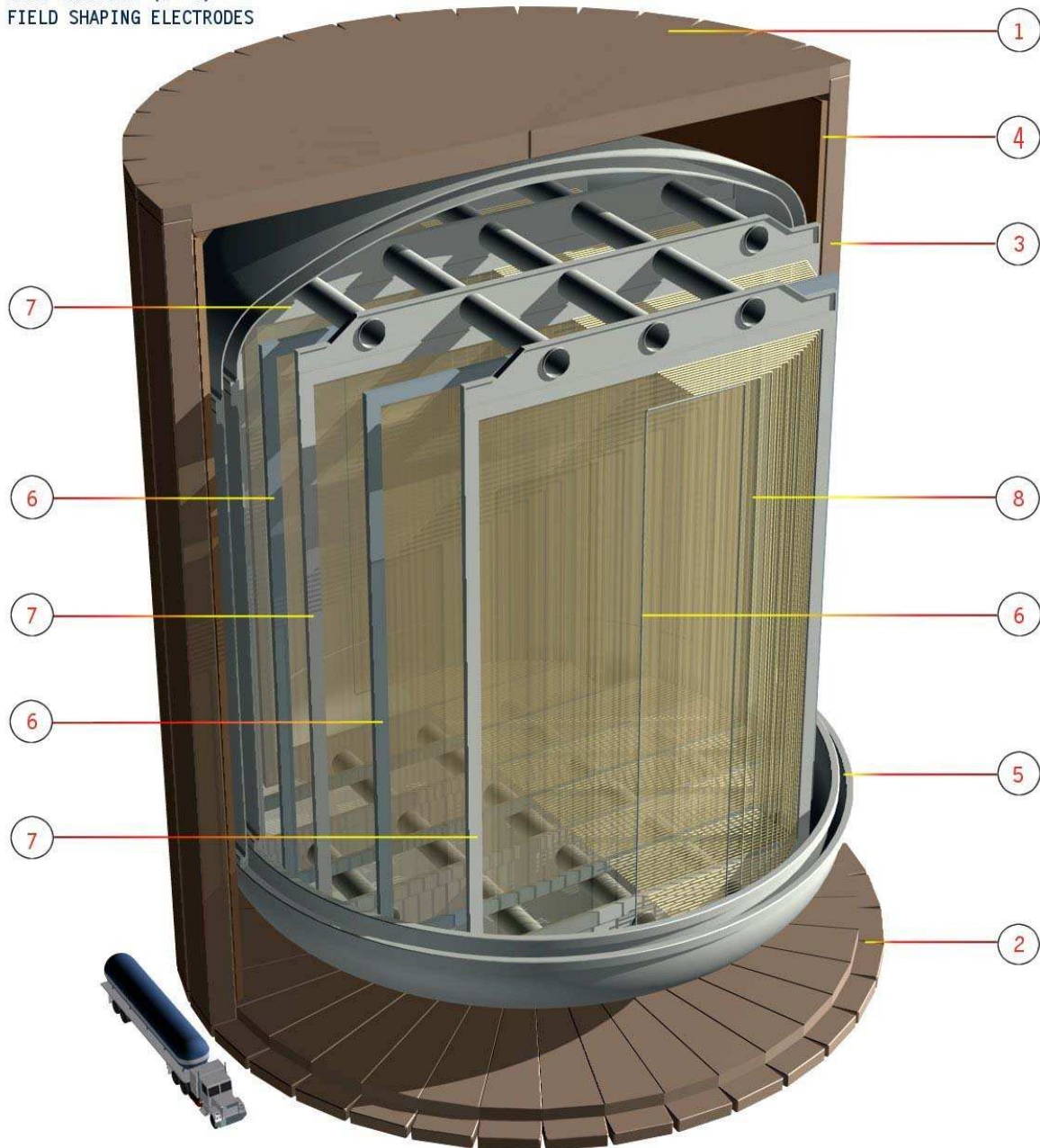

**LANNDD**  
Liquid Argon Neutrino and Nucleon Decay Detector

## Is a 100-kton Liquid Argon Detector Feasible?

- Use mature, low-cost technology of liquid methane storage tanks (up to 300 kton based on existing structures).  
Preliminary budget estimate from industry of  $< \$20\text{M}$  for a 100-kton tank, IF built on the SURFACE.
- 100 kton of liquid argon = 10% of USA annual production.  
 $\Rightarrow$  Deliver one trailer-load every 2 hours from Chicago,....  
Only 5 ppm  $\text{O}_2$  grade available in large quantities,  
 $\Rightarrow$  On-site liquid-phase purification via Oxisorb (MG).  
Raw material, delivery + purification  $\Rightarrow$   $\$0.8\text{M}/\text{kton}$ .
- ICARUS electronics from CAEN @  $\$100/\text{channel}$ .  
3 mm wire spacing  $\Rightarrow$  300k ch  $\Rightarrow$   $\$30\text{M}$ .  
9 mm wire spacing  $\Rightarrow$  100k ch  $\Rightarrow$   $\$10\text{M}$ .  
High capacity of long wires  $\Rightarrow$  signal may be too weak to use 3 mm spacing.
- With neutrino beam, record every pulse ( $10^{-3}$  duty factor).  
Cosmic rays occupy  $\approx 10^{-3}$  of active volume,  
 $\Rightarrow \approx 10$  MB data per trigger.  
 $\Rightarrow$  Modest ( $< \$10\text{M}$ ) DAQ/computer system.

# 200-kton Cryogenic Tanks Used for LNG Storage

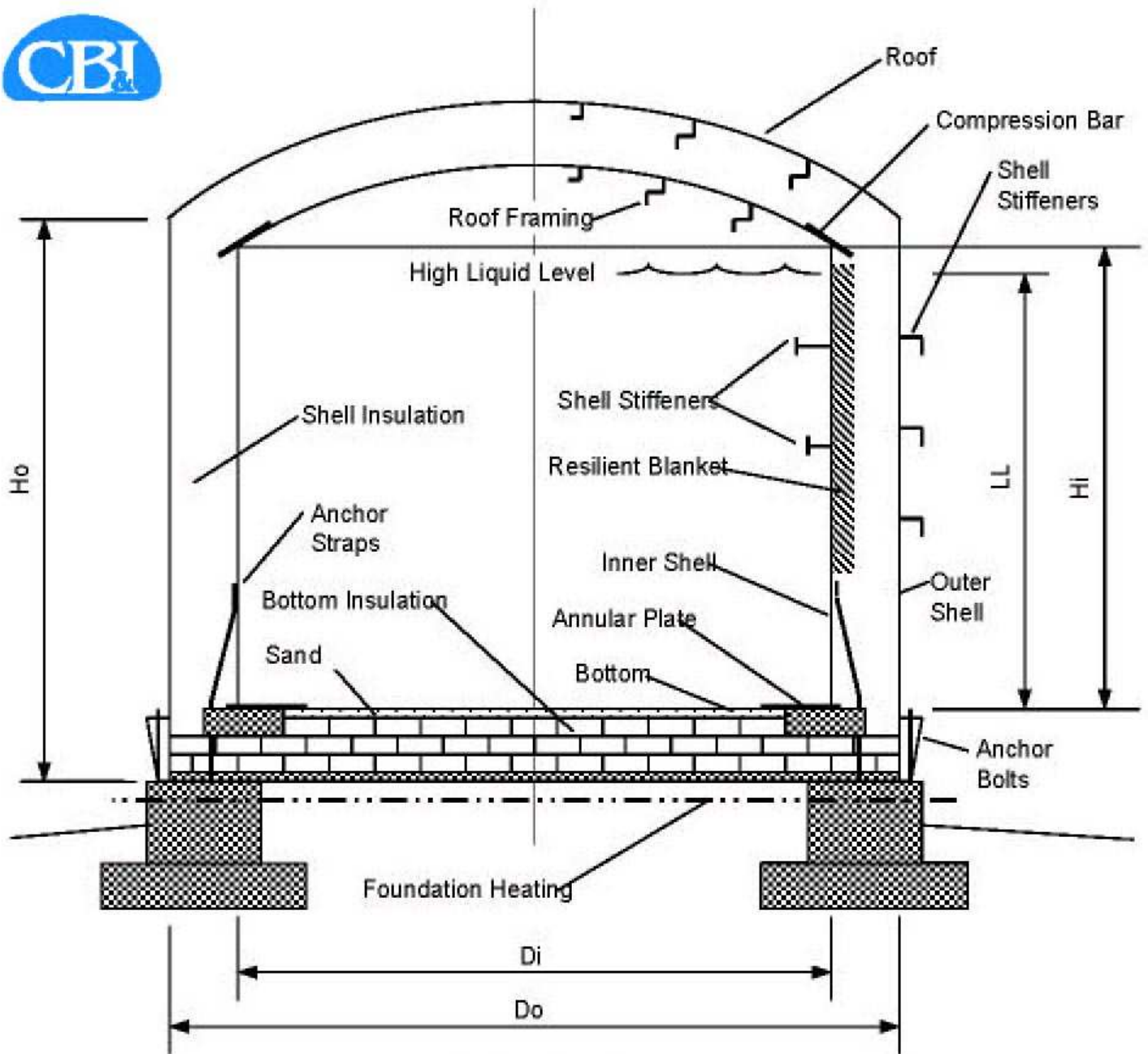

**Double Wall & Double Roof Tank**

	Feet
Di =	165
Hi =	117.9803
LL =	117.7303
Do =	173
Ho =	118.0443

Chicago Bridge & Iron: can build 100-kton LAr tank for < \$20M.

# Cryogenic LNG Storage Tanks

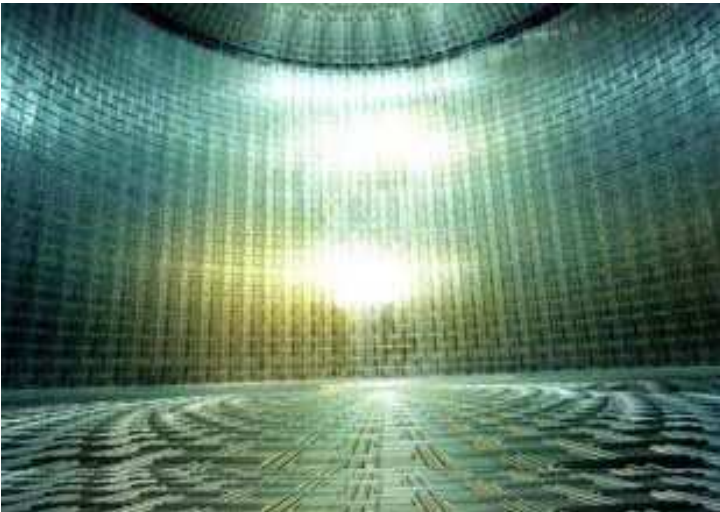

# Strong Interest by Praxair

Praxair is the leading USA vendor of liquid argon.

The Praxair R&D Lab in Tonawanda, NY is same Union Carbide lab that provided the expertise to build the Oak Ridge gaseous diffusion plant in the 1940's.

## LANNDD Cryogenic System

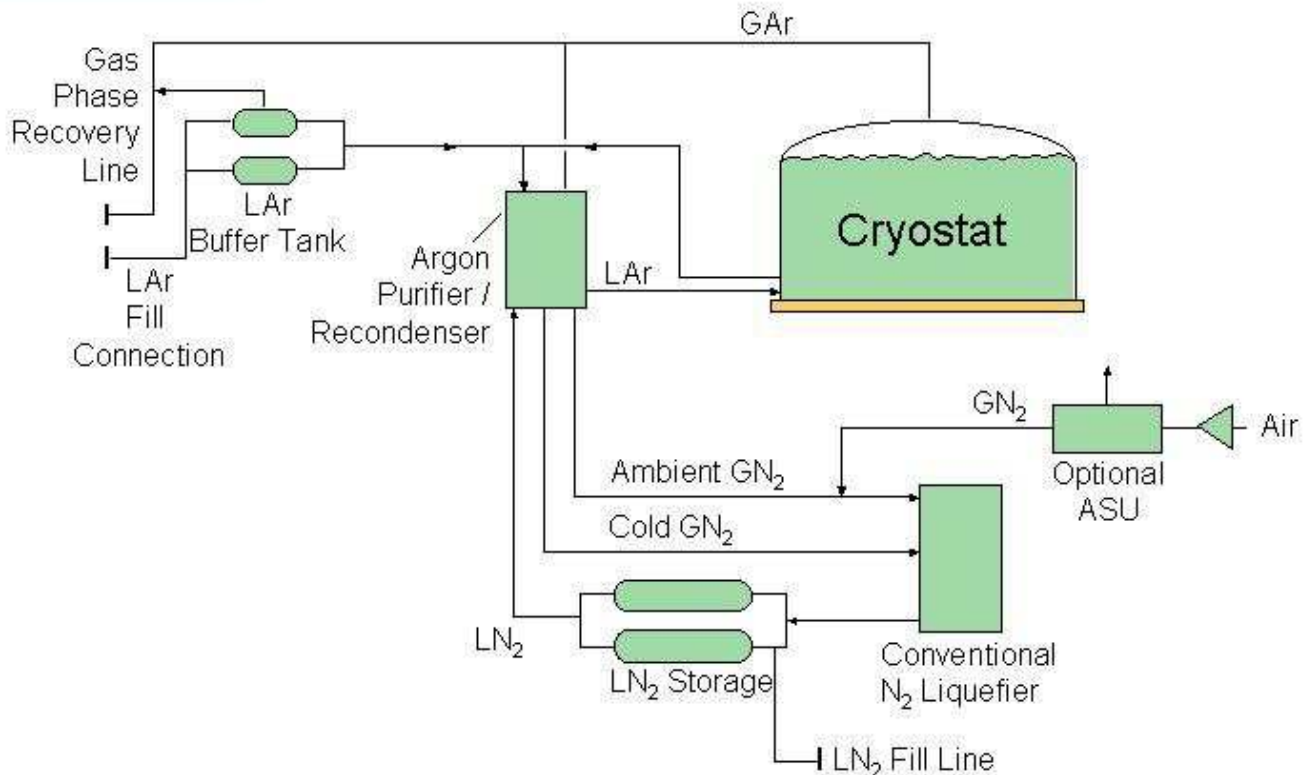

PRAXAIR BUSINESS CONFIDENTIAL

ami:9/2002-DPB 1

## 100 kton of Liquid Argon as a Detector for $p \rightarrow K^+ \bar{\nu}$

Efficiency for this mode is  $\approx 10$  times that of water Čerenkov.

This mode favored in many SUSY models.

## Can a Proton Decay Search Be Done at the Surface?

- The signature of the decay  $p \rightarrow K^+ \bar{\nu}$  is particularly clean:

$$K^+ \rightarrow \pi^+ \rightarrow \mu^+ \rightarrow e^+.$$

$\Rightarrow$  Maybe “no background” to  $10^{35}$  year even at surface.

Worry:  $\approx 10^5$   $n+p \rightarrow K^+ \Lambda(\Sigma)$  per Mton-year (astro-ph/0208381).

- Need 100% duty factor for proton decay search.

$\Rightarrow \approx 10$  GB/sec data rate at surface.

- May need to go underground (100 m?) to suppress the data rate.

$\Rightarrow$  Additional \$100M to site detector underground.

- Cheaper to buy a big DAQ system and operate at the surface  
– if backgrounds are OK there.

## Budget Estimate (Very Rough)

For a 100-kton detector at the surface:

Component	Cost
Liquid argon (industrial grade)	\$70M
Cryo plant, including Oxisorb purifiers	\$10M
Surface site preparation	\$10M
Cryogenic storage tank	\$20M
Electronics (300k channels)	\$30M
Computer systems	\$10M
Subtotal	\$150M
Contingency	\$50M
Total	\$200M

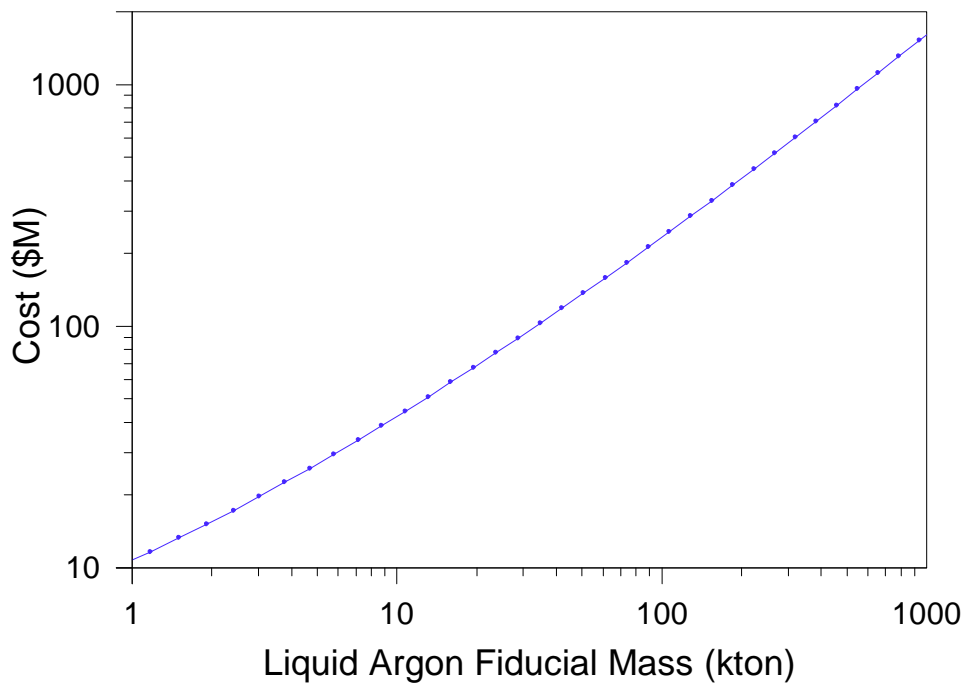

## Next Steps

- 40-ton near detector (1.5-ton fid. mass) in off-axis NUMI beam.



- Add Chicago Cyclotron Magnet coils to give  $B \approx 1$  T over downstream (or upstream) 2/3 of detector.

*Chicago Cyclotron Magnet coil*

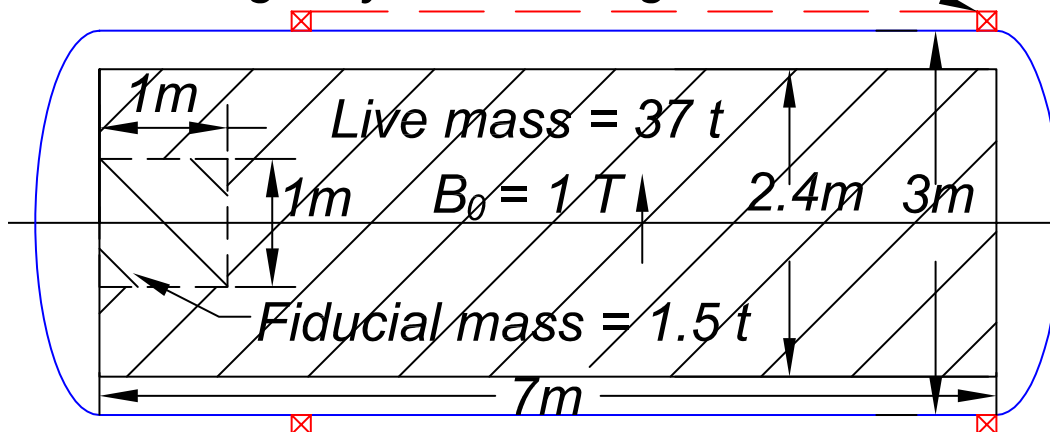

$\Rightarrow 10^5$  CC  $\nu_\mu$  interactions/year.

LAr Near Detector “premeeting” at SLAC, Jan. 23, 2003.

## R&D (see NuMI-PUB-GEN-0880)

- Liquid-phase purification of industrial grade argon via Oxisorb or equivalent (Praxair).
- Mechanics and electronics of wires up to 60-m long.
- Cryogenic feedthroughs, possibly including buffer volume at 150K for low-noise FET's.
- Verification of operation of a liquid argon TPC at 10 atmospheres (as at bottom of a 100-kton tank).
- Study of liquid argon TPC in a magnetic field (BNL P-965).

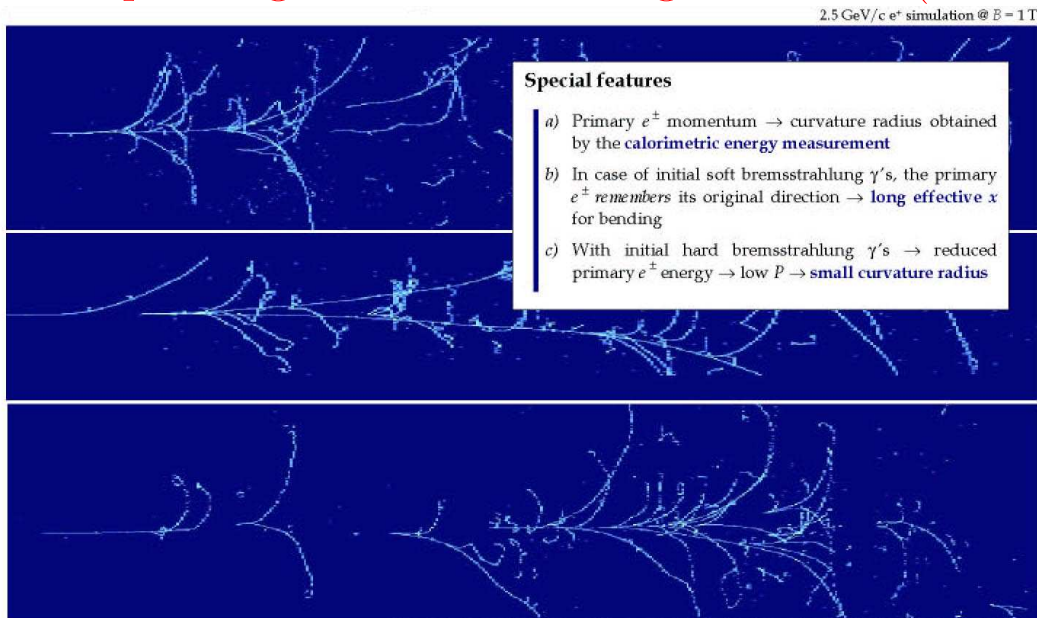

A. Bueno, M. Campanelli, A. Rubbia, IX International Workshop on "Neutrino Telescopes", VENICE, 2001

Should identify sign of  $e^\pm$  up to  $\approx 3$  Gev in a 0.5-T field.