

MuBSy
Id.: INTRO
Version: 2.2
Date: January 14, 2000
Revised: January 14, 2000

M_{ulti} **B**_{ranch} **S**_{ystem}

GSI Multi-Branch System User Manual

R. Barth, Yifei Du, H.G. Essel, R. Fritzsche,
H. Göringer, J. Hoffmann, F. Humbert,
N. Kurz, R.S. Mayer, W. Ott, D. Schall

January 14, 2000

GSI, Gesellschaft für Schwerionenforschung mbH
Planckstraße 1, D-64291 Darmstadt
Germany
Tel. (0 6159) 71-0

List of Figures

2.1	Environment Tasks	9
3.1	Hardware Configuration with CVC	19
3.2	Hardware Configuration with VME	20
4.1	Local Commands and Messages	22
4.2	Local and Remote Commands and Messages	27
5.1	Connections and Servers	36
6.1	Branch and Pipes	47
6.2	Buffers and Streams	49
7.1	Multi-Layer Structure	66
10.1	Histogram Access, one Base	108
10.2	Histogram Access, two Bases	109
10.3	Histogram Data Base Structure	110
10.4	On-line Analysis Flow Chart	113

Chapter 1

Preface

GMC_EDIT

GOOSY Copyright

The GOOSY software package has been developed at GSI for scientific applications. Any distribution or usage of GOOSY without permission of GSI is not allowed. To get the permission, please contact at GSI Mathias Richter (tel. 2394 or E-Mail "M.Richter@gsi.de") or Hans-Georg Essel (tel. 2491 or E-Mail "H.Essel@gsi.de").

MBS Copyright

The MBS software package has been developed at GSI for scientific applications. Any distribution or usage of MBS without permission of GSI is not allowed. To get the permission, please contact at GSI Mathias Richter (tel. 2394 or E-Mail "M.Richter@gsi.de") or Hans-Georg Essel (tel. 2491 or E-Mail "H.Essel@gsi.de"), or Nikolaus Kurz (tel. 2979 or E-Mail "N.Kurz@gsi.de").

Conventions used in this Document

Examples in this manual show both system output (prompts, messages, and displays) and user input, which are all written in `typewriter` style. Names and keywords are also in `typewriter` style. Items to be replaced by actual values are enclosed in `<>`.

The change bars mark changes between MBS and SBS.

Registered Trademarks are not explicitly noted.

1.1 Intended Readers

GSI Multi-Branch System User Manual:

1.1.1 New Users of MBS

Overview Chapter 2, page 7

Hardware Chapter 3, page 17

Command Interface Chapter 4, page 21

Running a Data Acquisition Chapter 5, page 29

Event Serving and Filtering Chapter 9, page 87

1.1.2 Experienced Users of SBS

Release Notes Chapter 14, page 143

Readout Control Chapter 6, page 47

Multi-Layer Multi-Branch Systems Chapter 7, page 65

Data Structures Chapter 8, page 73

1.1.3 Optional Facilities

Histogramming Chapter 10, page 107

1.1.4 Reference Chapters

ESONE Library Chapter 11, page 117

Keyword Summary Chapter 12, page 121

Command Summary Chapter 13, page 135

1.1.5 List of all Chapters

Overview Chapter 2, page 7
Hardware Chapter 3, page 17
Command Interface Chapter 4, page 21
Running a Data Acquisition Chapter 5, page 29
Readout Control Chapter 6, page 47
Multi-Layer Multi-Branch Systems Chapter 7, page 65
Data Structures Chapter 8, page 73
Event Serving and Filtering Chapter 9, page 87
Histogramming Chapter 10, page 107
ESONE Library Chapter 11, page 117
Keyword Summary Chapter 12, page 121
Command Summary Chapter 13, page 135
Release Notes Chapter 14, page 143

1.2 Other Manuals

1.2.1 GSI Multi-Branch System Reference Manual

Command and function descriptions.

1.3 MBS Authors and Advisory Service

The authors of MBS and their main fields for advisory services are (phone GSI: + 6159 71 -):

R. Barth Fastbus SMI library (Tel. 2554)

Y. Du Event routines, DECunix port, AIX port (1995-1996)

H.G. Essel Multitasking, CI, message logger, ESONE, GOOSY connections (Tel. 2491)

R. Fritzsche TCP library.

H. Göringer Event server, PAW connections (Tel. 2553)

J. Hoffmann CVC hardware, trigger (Tel. 2494)

F. Humbert Esone library (1996)

N. Kurz Lynx, setup, readout, collector, multi-branch systems (Tel. 2979)

R.S. Mayer Event server, error/message handling (1992-1995)

W. Ott Message logger, transport, stream server, taping (Tel. 2979)

D. Schall CVC hardware, trigger (left GSI in 1996)

The authors thank Margareta Hellström and Piotr Koczon for useful hints and for reviewing this manual resulting in substantial enhancements. Further suggestions to enhance the manual are welcome. The manuals are accessible also through WWW:

<http://www-gsi-vms.gsi.de/img/doc> or

<http://www-gsi-vms.gsi.de/daq/home>

H.Essel@gsi.de.

Chapter 2

Overview

GMC_MBS_INTRO

2.1 Summary

The **Multi-Branch System (MBS)** runs under the operating system Lynx OS (v2.5), a realtime UNIX system. Almost all of the software is written in GNU C. The tcsh shell must be used in order to run the system. The software runs on the GSI developed CAMAC processor board CVC, on the ELTEC E6 and E7 VME processors and on VME PowerPC platforms (CES RIO2).

Although the data acquisition system is called Multi-Branch System (MBS) it is in fact scalable from small single-crate CAMAC or VME systems, single branch systems with multiple intelligent controllers to large hierarchical structured (multi-layered) multi-branch systems. CAMAC, VME and FASTBUS are supported. The data bus between crate controllers and event builders can be memory mapped like VME bus, differential VSB bus and PVIC (CES), or transfer oriented like Ethernet.

The data access from the controller which controls the branch (branch master) to slave controllers is provided by address mapped windows. These address windows can be specified freely in a setup database (multi-window system). The system works standalone, i.e. no other computers are necessary to take data and store it on a local tape. For on-line analysis, however, workstations are needed (i.e. running GOOSY or PAW).

2.2 Command Interface

The MBS is controlled from ASCII terminals (VT type) through a command interface. The MBS commands are composed of up to three command keywords followed by named arguments and qualifiers. The commands are not implemented directly in the shell. They are dispatched from dispatcher or prompter programs and executed by tasks running either on local or remote nodes.

Command and argument specification can be stored in text files. Each command is executed by a routine. All keywords may be abbreviated, e.g.

```
SET VERBOSE EVENT or SET VER EV
START TASK          or STA TA
```

The command arguments can be input in a positional order, by name reference or as qualifiers:

```
START TASK <name>
START TASK file=<path> name=<task>
SHO COMMAND -FULL
```

The interface executes command files and allows for recalling of command lines. **All command input except strings enclosed in "" or beginning with a slash is changed automatically to lowercase as the command definitions are.** See more in 4, page 21.

2.3 Help

The documentation of all MBS commands and modules is done using the GSI documentation tools. The help libraries are available on Lynx by command `help`. It works similar as the VMS `HELP`.

```
help          list of available libraries
help -<lib>   content of specified library
help -<lib> <key1> next level
help <key>    search key in all libraries
help -mbs     MBS help library
help -goosy   GOOSY help library (DAQ commands)
```

Currently the mbs help file `mbs.hlp` is generated on OpenVMS and then moved to directory `$HELPDIR = $MBSROOT/lib`. The helpfile is generated from `$MBSROOT/set/mbscom.cdf` and `$MBSROOT/set/utilcom.cdf`.

2.4 News

There is a news tool which can be called from shell or from dispatcher by command `news`. Currently news for lynx and for daq are available:

```
news          (get list of available news)
news daq      (get list of unseen topics)
news lynx
news daq -a   (get list of all topics)
```

The news files are on directory `$NEWSDIR = /mbs/news`.

2.5 MBS Environment

Software Components

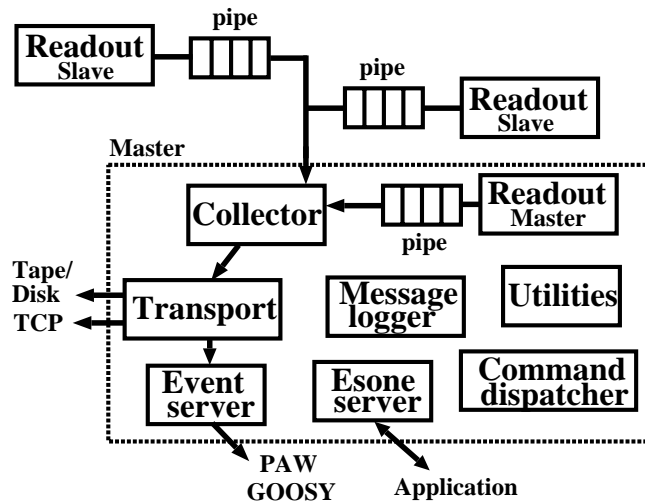

Figure 2.1: MBS Components

Figure 2.1 shows the main components of MBS which will be described briefly in the following sections. MBS *components* are *tasks* executing commands. Both terms are used in this manual. These components can be started from the shell or run in background. In the first case, they get the commands from the terminal, in the second case from a *dispatcher* program. Thus several components can be controlled from one terminal.

The set of components controlled from one terminal is called *environment*. There are one *local* and optionally several *remote* environments. Each environment has one dispatcher and one *message logger*. On the node of the local environment the *prompter* is used to dispatch commands. If there are no remote environments, the dispatcher is used instead of the prompter.

The tasks communicate through common memory sections or message files. There are two kinds of tasks: *Known* and *Unknown*. Tasks which execute commands must be known to the dispatcher, because the dispatcher must send the commands to these tasks. These *known tasks* are forked (started in background) directly by the dispatcher by the `START TASK` command. The dispatcher can also start tasks which do not execute commands. These *unknown tasks* are forked as childs of the Lynx INIT task. They are shown as *detached* by the dispatcher. Known tasks can only run once at the same time.

2.5.1 Command Dispatcher

See figure 2.1. This program (`m_dispatch`) is started by alias `mbs` to control components running in its environment. It can be called only once on a Lynx system. It executes the following functions:

- Start message logger.
- Start/Stop tasks.
- Dispatch Commands.

The components are forked. MBS commands are dispatched to the task where the command is executed. The dispatcher hibernates until it gets an acknowledge message from the task. The tasks executing the command can use the terminal for output, but should normally send their output to the message logger (see below). The dispatcher can be left by commands `EXIT` or `QUIT` and restarted. It then acknowledges all known tasks. **Do not leave the dispatcher by CTRL-Z! This kills all tasks.** See also 4.2, page 21.

2.5.2 Message Logger

See figure 2.1. This program (`m_msg_log`) is started automatically when running the dispatcher or prompter. It accepts messages and writes them to the log-file (`mbslog.1`) and/or to the terminal. If the message logger is not running, all tasks sending messages will wait (including the dispatcher). When started by the prompter the message logger acts as a message server. It then accepts TCP connections from other remote message loggers (clients).

2.5.3 Prompter

This program (`m_prompt`) is started by alias `prm` to control components running in remote environments. It can be called only once on a Lynx system. It executes the following functions:

- Start message server.
- Start remote dispatchers and message loggers (clients).
- Connect/disconnect remote dispatchers.
- Dispatch Commands to remote dispatchers.

The nodes of the environments to be controlled by the prompter must be listed in a text file, one per line. The default file is `node_list.txt`. The remote dispatchers are started by the prompter using remote shell commands `rsh`. The prompter then connects to them via TCP. MBS commands are dispatched to the specified node. The prompter hibernates until it gets an acknowledge message from the remote dispatcher. The prompter can be left by command `EXIT` or `QUIT` and restarted. It then connects to all nodes found in a file `node_list.txt` on the current directory. **Do not leave the prompter by CTRL-Z!** See also 4.7.1, page 25.

2.5.4 Readout

See figure 2.1. The *master* readout (`m_read_meb`) runs on the node controlling an individual (single) branch. The event readout is triggered either by an interrupt or by polling a trigger bit in some hardware register (normally from the GSI trigger module). It reads the local crate and optionally other crates equipped with non intelligent crate controllers. The readout can be specified either through user written readout functions or in the case of a pure CAMAC setup through simple readout tables. These tables have to be written as text files and must be loaded by command.

The *slave* readout (`m_read_cam_slav`) runs on CVCs in slave CAMAC crates. It polls on the local interrupt bit from the trigger module. The readout specification is done either through user readout functions or CAMAC readout tables like for the `m_read_meb`.

All readout tasks write their data into a configurable subevent pipe.

See also 6, page 47, 5.2.3, page 30 and 8.1.3, page 77.

2.5.5 Collector

See figure 2.1. The collector (`m_collector`) normally composes events from the subevent pipes filled by the readout tasks and formats GSI buffers (format see page 82). It also provides a user function interface for on-line histogramming and/or early data analysis including event rejection. Formatted streams of buffers are passed logically to the transport task which writes them to the output channels (tape, disk, TCP). In the case of a multi-layered system the user may specify if the collector formats either events into GSI buffers or writes the data collected from subevent pipes unformatted into an output pipe to be collected by a next layer collector. These two options may be set up to run simultaneously. See 7, page 65.

2.5.6 Transport

See figure 2.1. The transport task (`m_transport`) can write all data buffers to tape or disk, to network (TCP), or both. After startup all data buffers are simply discarded by the transport. The output channel to a tape drive is opened after mounting a tape and opening a file by command. The TCP channel must be enabled with the command `ENABLE TCP`. When a clients connects all buffers are sent to this client. When tape writing was active, buffers are written to tape **and** the TCP channel. To write to tape **or** network exclusively, TCP must be enabled by `ENABLE TCP -EXCLUSIVE`.

All output channels are synchronous, which implies that the data acquisition will block, if the selected output channels are not ready to take the data. See also 9, page 87. A GOOSY transport manager may connect as client (GOOSY command `CONNECT TRANSPORT`). The transport also passes streams already written to its synchronous output channels to the optionally running event or stream server for data/event monitoring purposes. See also 9.2, page 88.

2.5.7 Event Server

See figure 2.1. The event server (`m_event_serv`) runs optionally to send samples of the data to connected clients. Clients could be GOOSY analysis programs or PAW programs in the same way as for the GOOSY-PAW server. The clients may specify filter conditions to select events (See 9.10, page 101). The event server gets buffer streams processed by the transport and marks them free after processing. Events are copied to event buffers for the clients. After startup of the task the event server must be activated by MBS command `START EVENT_SERV`. See also 5.4, page 36 and 9.5.2, page 92. There is also a *remote* event server which runs on all GSI platforms (OpenVMS, AIX, DECunix). It gets data from the stream server (see below). Clients may get events from the local or remote event server in the same way. See also 9.4, page 89.

2.5.8 Stream Server

The stream server task (`m_stream_serv`) may run alternatively and exclusively to the event server. It writes on request list mode data samples (streams) to a connected client (TCP). A GOOSY transport manager (GOOSY command `CONNECT STREAM`) or a remote event server may connect. See also 9.1, page 87.

2.5.9 Esone Server

See figure 2.1. The Esone server (`m_esone_serv`) executes buffers containing CNAF lists. The buffers are filled and returned to the client. A client library is available on all GSI platforms. See also 5.3.3, page 35.

2.5.10 Histogram Manager

The histogram manager `m_histogram` executes commands to handle histograms. See 10, page 107.

2.5.11 Utility

The program `m_util` executes most of the MBS commands. To execute single commands, this program also may be called from shell by alias `util`.

2.6 Standalone Programs

All standalone programs are called by alias names. The actual list can therefore be printed by command `alias`.

- `mbs`: start dispatcher.
- `prm`: start prompter.

- `daq_mon`: monitors the activities of the system. It needs its own terminal because it does continuous output and displays two pages of information in a toggling mode. The toggle time can be specified by `-ts` where s are seconds, with 30s as default. If only one page of information should be displayed, it can be specified with `-p1` or `-p2`.
- `inimbs`: Create and/or initialize control structure. (**To be used only, when all tasks are stopped!**).
- `msg_sho`: sho status of message files.
- `msg_new`: delete and create message files (must be first action after reboot).
- `help`: call help.
- `news`: call news.
- `rate`: Show data acquisition rate (continuously). The time interval can be specified by `-ts` where s are seconds. Leave it by CTRL C.
- `camac`: Execute local cnafs.
- `tasks`: Show tasks status in MBS control structure.
- `remote`: Executes commands on remote nodes. `show` shows environment tasks on remote nodes, message status and netstat. `reset` kills environment tasks on remote nodes, cleans message files and DAQ status.

```
remote SHOW/RESET -LOCAL # on local node
remote SHOW/RESET <node> # on remote node.
remote SHOW/RESET @<file> # nodes from file.
```

- `send`: Send one command line to a prompter for execution. The prompter must have been started with `-r <node>` where node specifies from where `send` commands are accepted. This command is provided to be used in shell scripts.

```
send e7_10 sho task
```

2.7 Software Organisation

2.7.1 File Organisation

Production and Development

The MBS software is kept in two versions: The production version and the development version. The difference is in the directory path: `/mbs/prod` and `/mbs/deve`. Users should use the production software. All file references in the MBS software are prefixed by the environment variable

MBSROOT. This variable is changed by commands `deve` and `prod`, respectively. There are alias names specifying path and filename (without the leading `m_`) to call programs, i.e. `msg_log` to call `/mbs/prod/bin_CVC/m_msg_log`. These aliases always point to the selected software version.

Directories

The main directories of the MBS software are (below MBSROOT):

- `/bin_${HOSTTYPE}` : Programs and shell scripts for different platforms, i.e. E6, E7, CVC.
- `/src` : Sources.
- `/lib` : Help and object libraries.
- `/set` : Parser definition files, profiles, command definition files.
- `/inc` : Include files.
- `/script` : Script files.
- `/exa` : Examples.

The following are above MBSROOT (same for `prod` and `deve`):

- `/mbs` : (Top directory) Alias definition script, MBS login scripts.
- `/mbs/news` : News files (`.inf` and `.txt`).

2.7.2 Naming Conventions

File Names

Sometimes it is useful to mark files with a certain content by filename extensions (i.e. `setup.usf`, where `usf` stands for `user setup file`). The advantage is, that one can select the files in directories, but need not specify the full name in commands, where there are defaults for the extensions. For example, help files have the extension `.hlp`, but in commands you can omit this extension. The following is a list of extension defaults recognized in MBS:

- `.pdf` : Parser definition file. Text file containing definitions for setup files.
- `.usf` : User setup file. Text file containing parameters and values describing the setup.
- `.mrf` : Master readout file. Text file containing specifications for CAMAC readout tables.
- `.urf` : User readout file. Text file containing CAMAC readout tables.
- `.sc` : Script files.
- `.hlp` : Help text file used in `help` command. A text file structured like VMS help files.
- `.cdf` : Command definition file. Text file with command definitions.
- `.inf` : News directory file. Text file containing a list of topics pointing to `.txt` files.
- `.txt` : News text files. Contains news text.
- `.l` : Log file.
- `.scom` : Command procedure. Text file containing command lines.

Environment Variables

MBS sets some environment variables:

HOSTTYPE	CPU type, should not be changed
MBSROOT	root directory, is changed when switching to MBS development version
HELDIR	help directory, may be changed to different directory to get help from private libraries, see below
NEWSDIR	news directory, may be changed to different directory to get private news, see below

2.7.3 Profile Interface

The MBS profile system uses two types of text files: The parser definition files (typically names ending `.pdf`) and the profiles (filenames ending `.usf`, `.mrf`, `.urf`). In programs one may use a set of routines to get values from profiles by name references. This tool which is very versatile can also be used by users writing their own profiles. See also 8.1, page 73 and 5.2.2, page 30.

Chapter 3

Hardware

GMC_MBS_HARD

3.1 Single-Branch Systems

In the MBS data acquisition software various hardware setups are supported. MBS can be used as a single-crate, or a single-branch system (VME or CAMAC), because up to 16 crates may be connected via one differential VSB bus. In addition, several single-branch systems can be combined to full fledged hierarchical structured multi-branch systems. The software design requires up to now, that read/write access from the branch master to it's slave crate controllers is provided through remote address-mapped windows. It doesn't rely on a specific hardware protocol unless it is address-mapped. Presently, only the VME and VSB buses fulfill this requirement.

In this section only single-crate and single-branch systems are described. The description of multi-layered multi-branch systems follows in a separate chapter (7, page 65).

The MBS requires that each crate must be equipped with a crate controller, either intelligent (i.e. equipped with a processor running an operating system) or non-intelligent. Supported crates and crate controllers are:

CAMAC: CVC (LynxOS), CBV, CVI (pSOS), CAV (all developed at GSI)
VME: E7 and E6 (LynxOS), PowerPC board (LynxOS) (planned)
FASTBUS: Aleph Event Builder AEB with the VSB interface EBI (OS-9),
Lecroys Segment Manager Interconnect SMI with VSB interface FIFA,
STRUCK STR340/SFI module with two internal VME processor slots

One of the intelligent controllers running under the LynxOS operating system must be designated as the branch master, i.e. must have read/write access to remote subevent pipes. In VSB based systems it has therefore to be the VSB master to read/write from/into the VSB slave address window. To set a CVC as VSB master the front panel switch has to be set to 0 and the CVC rebooted. E6 and E7 work per default simultaneously as VSB master and - slave. The

AEB-EBI running under OS-9 is not allowed to be branch master, therefore one needs a CAMAC or VME system for event building. Similarly the SMI-FIFA setup needs a readout processor in CAMAC or VME. With the new Struck FASTBUS Interface SFT340 it is possible to run Fastbus single-crate systems stand-alone in combination with a VME processor board and a VME trigger module.

Apart from the branch master all controllers run as VSB or VME slaves. This is done by setting the front panel switch to a non-zero value for the CVC and the AEB-EBI and rebooting it. Also the non-intelligent crate controllers like CBVs must get a unique crate number by setting the front panel switch to a non-zero value. On an E7, a specific slave VSB and VME address window can be set by the upper front panel switch. For the E6 an internal chip has to be programmed to set the VSB slave address window.

The branch master reads the hardware modules in all crates equipped with non-intelligent crate controllers and/or its own crate. Intelligent slave controllers read only their local crate.

Each intelligent controller which has to perform hardware readout has to be triggered by its GSI trigger module. Two modes of trigger operation, interrupt and polling, are supported and specified in the setup file. In interrupt mode, the trigger module must be housed in the same crate as the controller. In polling mode, the controller needs address-mapped access to the internal register of the trigger module which can be therefore located in the local or in a remote crate. Trigger modules are available with the same functionality for all supported crate types (CAMAC, VME, and FASTBUS). All trigger modules in a system must be connected via a trigger bus cable to ensure synchronisation of the hardware readout. One trigger module in a system must be designated as master trigger module. It gets the trigger inputs and distributes them via the trigger bus cable to the slave trigger modules. The master trigger module must be controlled by a LynxOS crate controller, but can be in any crate. The trigger module allows for 15 different trigger sources, called *trigger types*. Trigger type 14 and 15 are used by the system to start and stop the readout, the remaining types 1-13 are free for the user.

The minimal hardware requirements for a single-VME or CAMAC crate system are:

VME crate + E6 or E7 + VME trigger module
or CAMAC crate + CVC + CAMAC trigger module

There are more hardware configurations supported. This includes for example systems with multiple VSB branches, or systems with two CVCs as master and slave in a single-crate, both increasing the performance substantially. Ask the DAQ people if you need a configuration not covered by this description.

3.2 Single-Branch Hardware Setup Examples

3.2.1 One VSB Branch

In figure 3.1, page 19 one can see an example with CAMAC computer boards (CVC). The VSB is the branch. The board is fully equipped with a 68030 processor, ethernet, SCSI and VSB.

Several different subsystems may be connected to the VSB, i.e. other CAMAC crates with CVCs or Fastbus crates with Aleph Event Builders (AEB) or LeCroy's Segment Manager Interconnect (SMI). The standard software version assumes that each readout processor is triggered by a GSI trigger module.

3.2.2 One VME Branch

Figure 3.2, page 20 shows an example of a VME based setup. The VME bus is the branch. The MBS is running on ELTEC VME CPU boards (E6, E7) under Lynx. (see also figure 6.1)

Hardware Configuration

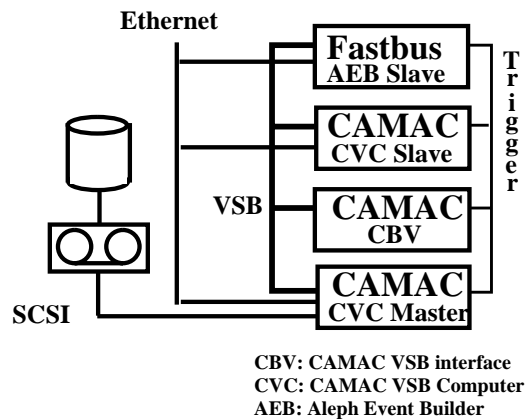

Figure 3.1: Hardware Configuration with CVC

3.3 Performance Measurements

There are some measurements of the performance of the system on different hardware configurations. Note that we used a fixed pulser and a conversion time of zero. The numbers represent therefore the absolute maximum one will not achieve in real life.

Data Transfer VSB to CVC (CAMAC 68030):
 Distance 1 m : 2.7 MB/sec, 15 m : 2.4 MB/sec
 One CVC, one CAMAC crate:
 One word events : 2.2 KHz
 700 word events : 900 KB/sec

Hardware Configuration

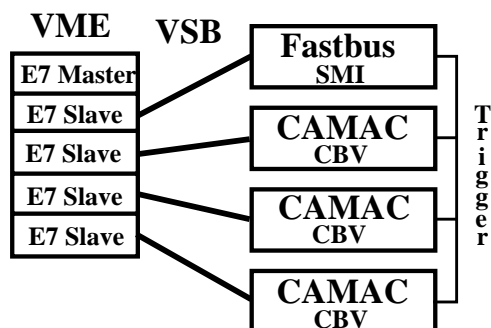

SMI: Segment Manager Interconnect
CBV: CAMAC VSB interface

Figure 3.2: Hardware Configuration with VME

600 KB/sec to tape (TZ87)
 240 KB/sec via TCP to client

One CVC, one CAMAC slave:
 One word events : 8.3 KHz
 500 word events : 1230 KB/sec
 760 KB/sec to tape (TZ87)

One CVC, two CAMAC slaves:
 1000 word events : 1400 KB/sec
 800 KB/sec to tape (TZ87)

One ELTEC E7 (VME), one CAMAC slave:
 One word events : 13.4 KHz
 500 word events : 1140 KB/sec
 1130 KB/sec to tape (TZ87)
 480 KB/sec via TCP to client

One ELTEC E7 (VME), two CAMAC slaves:
 1000 word events : 2040 KB/sec
 1230 KB/sec to tape (TZ87)

Chapter 4

Command Interface

GMC_MBS_COMIN

The MBS command interface runs on Lynx, AIX, HP-UX, DECunix, and OpenVMS. Dispatcher and message logger run only on Lynx and DECunix.

4.1 Local Environment

In a *local environment* (see figure 4.1, page 22) a dispatcher accepts terminal input, forks tasks, and dispatches commands to these tasks. It is started by alias `mbs`. It starts a local message logger. All tasks send their output to this message logger which in turn writes them to the log-file `mbslog.1` and/or to the terminal. In the following we give a short summary of most often used commands to control the tasks.

```
START TASK
STOP TASK
SHOW TASK
SHOW COMMAND
QUIT
```

Tasks can be stopped in two ways. The softest way is `STOP TASK <name>`. Then the task executes the command `EXIT` and terminates. A harder stop is to kill known tasks by `STOP TASK <name> -KILL` and unknown tasks by `STOP TASK PID=<pid> -KILL`. Then the dispatcher kills the tasks sending the `SIGTERM` signal the same way as the Lynx command `kill <pid>` does. With qualifier `-ALL` all known tasks are stopped. Qualifier `-ZOMBIE` is useful if tasks terminated abnormally and are in `Z` status as shown by Lynx command `ps -axnt` (see also 5.5, page 38).

4.2 Line Input

A command line is composed by command keywords followed by arguments separated by spaces. **All command input except strings enclosed in "" or beginning with a slash is changed**

Communications (local)

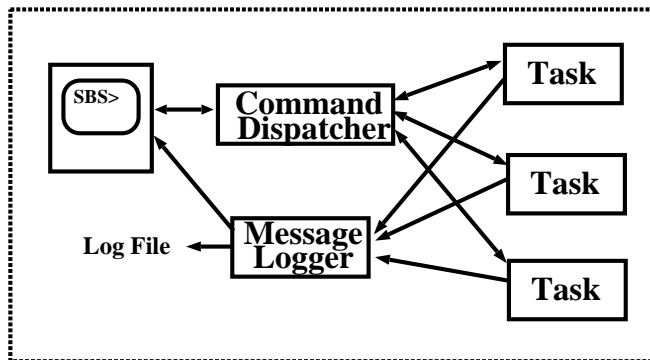

Figure 4.1: Local Commands and Messages

automatically to lowercase, as are the command definitions. Command keys and argument names can be entered in lower or upper case.

An MBS command line can be given in the following situations:

1. Input to a MBS component prompt, e.g. `m_util>`. The program must have been started stand-alone on shell level, e.g. by alias `util`.

```
$ util
m_util> <command>
```

2. Input to the MBS dispatcher (`mbs>`). An MBS environment and the appropriate task must have been created. (`mbs` is an alias for `m_dispatch`).

```
$ mbs
mbs> <command>
mbs> <task> <command>
```

Normally a command is executed in exactly one task. If it is defined in several tasks, the task name must be specified in front of the command followed by `>`.

3. Input to the MBS prompter. See next chapter.

4. In the shell. The MBS command must be preceded by the alias of the component, e.g. `util` or `mbs`. The first case is equivalent to (1), the second to (2). It is possible to use shell variables in the command line.

```
$ util <command>          ! execute one utility command
$ mbs <command>          ! Excute one MBS command
$ send <node> <command>  ! Excute one (remote) MBS command
```

4.3 Arguments and Qualifiers

The arguments can be written as positional values or by name reference. All keywords may be abbreviated. Required arguments are prompted.

Positional arguments are delimited by spaces. String arguments containing delimiters must be enclosed in quotes ("string"). Integer arguments can be entered in decimal, hexadecimal (0xn), octal (On), or bit (Bn) format. The arguments have names and may be specified in any order by `name=value`. The names are found in the help description of the command. A `??` gives a list of commands and `???` gives a list of commands with arguments. A command with `?` as argument gives the argument definition of the command.

Qualifiers are preceded by a space and a hyphen (`-qualifier`). They cannot specify a value.

4.4 Command Procedures

Command files are called by `@`. Extension `.scm` is assumed if only the name is specified. Command files may be nested. A backslash after the filename outputs the lines during execution. Arguments separated by spaces may be passed to command files. In the files, placeholders `$1` . . . `$8` are replaced by the arguments. Strings `\$` are replaced by `$` without replacement. Strings `\\` are replaced by `\`. In this case a following placeholder will be replaced. All text behind `#` is ignored, except `#` is inside `"`.

```
$ mbs @<file>
$ util @<file>\
mbs> @<file> <par1> <par2>
```

4.5 Defaults

There is currently no default mechanism except in the action routines!

4.6 Log File

As mentioned already most messages of MBS are written into a log file `mbslog.1` on the current directory. In the log file, each message is written together with the date, the time, and the node name. The log file is opened for append and closed for each message. Different kinds of messages are marked in the log file by one character between time and node name, i.e. `+` for commands, `#` for informations, and `!` for error messages. An example of a log file looks like:

```
12-Apr-95 13:38:46!CVC40 :dispatch :Command "set task -res" finished with error
12-Apr-95 13:40:26+CVC40 :event_ser:exit
12-Apr-95 13:40:42#CVC40 :stream_se:task m_stream_serv started
```

4.7 Remote Environment

4.7.1 Prompter

In *remote environments* (see figure 4.2, page 27) there are also dispatchers and message loggers, one on each node. These dispatchers are started remotely by the prompter. The prompter is started by alias `prm`. There are several ways to specify the nodes the prompter shall connect to.

```

prm                # nodes from file node_list.txt
prm -r <node>      # get input from send command from node.
prm [-r <node>] -n # no node at all
prm [-r <node>] -n <node> # one node
prm [-r <node>] -l  # local node
prm [-r <node>] -f <filename> # nodes from specified file

```

The prompter starts the dispatchers, as well as a local message server. It then connects to the dispatchers. The remote dispatchers start their message loggers as clients which connect to this message server via TCP. All commands are sent by the prompter to the destination dispatcher and then to the destination task. A task sends output to its local message logger which sends it to the message server where it is printed or logged into the log file.

4.7.2 Additional Prompter Features

The prompter changes its prompt string always to the node name of the default dispatcher, i.e.

```

$ prm
-CVC40:prompt    :connected to dispatcher CVC40, pid x
CVC40> SET DISPATCHER CVC38
CVC38> SHO DISPATCHER
-CVC40 :prompt   :connected dispatchers:
-CVC40 :prompt   : 0          CVC40 pid = 26
-CVC40 :prompt   : 0          CVC38 pid = 30
-CVC40 :prompt   :Current set dispatcher is CVC38

```

The default dispatcher is changed by command `SET DISPATCHER`. The prompter sends the commands to the default dispatcher. To send it to a different one, prefix it by `<node>::`. By prefix `*::` the command is sent to all connected dispatchers.

```

CVC40> CVC39::<command>
CVC40> *::<command>

```

The prompter can be left any time by `QUIT` and started again. All tasks continue to run. All output from the tasks still appears on the terminal. It is therefore not recommended to enter any editor. When starting the prompter in a running environment, it connects to all dispatchers

specified. This may take some time. When the remote nodes should be hanging, the command `REMOTE RESET -ALL` will cleanup all nodes, i.e. kill all MBS tasks, create new message queues, and clear the DAQ status table. The command does **not** cleanup the local node, because the local message logger may get still messages. To cleanup everything, one leaves the prompt and uses shell command `remote reset`. This command accepts either a node name or `@file` for the nodes to be cleaned up. See 5.5.4, page 39. Prompter commands:

```
CONNECT DISPATCHER
DISCONNECT DISPATCHER
SET DISPATCHER
SHOW DISPATCHER
REMOTE RESET
REMOTE SHOW
QUIT
```

The `DISCONNECT` command optionally kills the dispatcher (`-KILL`). The `REMOTE RESET` command kills all MBS tasks on specified nodes except the local node. Message files and DAQ status are reset. Example:

```
$ prm
CVC40> <command>
CVC40> CVC39::<command>
CVC40> *::<command>
CVC40> CONNECT DISPATCHER CVC38
CVC40> SET DISPATCHER CVC38
CVC38> SHO DISPATCHER
-CVC40 :prompt      :connected dispatchers:
-CVC40 :prompt      :  0          CVC40 pid = 26
-CVC40 :prompt      :  0          CVC38 pid = 30
-CVC40 :prompt      :Current set dispatcher is CVC38
CVC40> DISC DISPATCHER -ALL
prompt> CONNECT DISPATCHER -ALL
CVC38> REMOTE SHOW -ALL
CVC38> *::STOP TASK -ALL
CVC38> REMOTE RESET -ALL
```

Note that the messages are prefixed by a hyphen, the node name, and the task name (without leading `m_`). The `STOP TASK -ALL` command should be used to shut down all tasks if possible. It does not stop the remote dispatchers nor message loggers. Therefore one can immediately continue calling the startup procedure. After `REMOTE RESET` everything starts from scratch which takes much longer time.

Figure 4.2, page 27 shows how more nodes can be controlled from one terminal through the prompter.

Communications

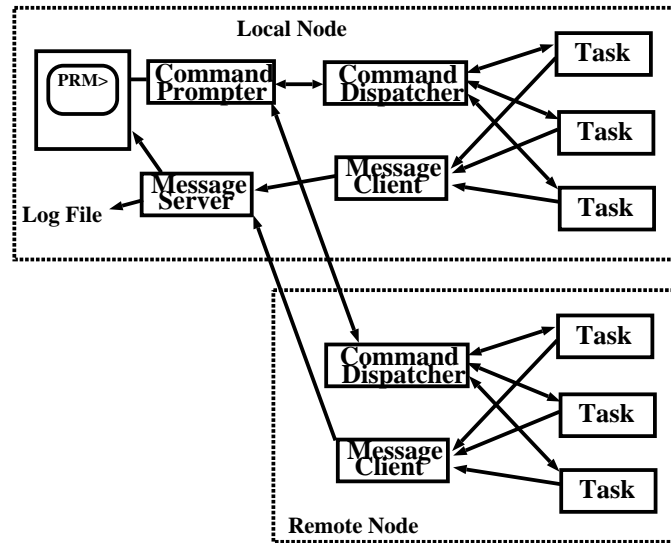

Figure 4.2: Local and Remote Commands and Messages

4.8 Motif Interface

On nodes providing motif a motif interface can be called. This feature is currently not used in MBS.

4.9 Command Example

The following command has two positional arguments and two switches. Command description:

```
START EVENT stream events maxclnt -verb
```

Valid commands are then

```
START EV 1 1000 # 1000 events from all streams
START EV max=3 # allow 3 clients
sta ev -verb # verbose output
```

An **invalid** command would be

```
STA EV -abc # Switch not known
STA EV abc # illegal value
```

4.10 User Defined Commands

Besides the commands provided by MBS the user may create his own commands and tasks. A description is found in `f_cmd.c`. An example can be found on VMS in the file `TOOL$examples:m_cmd_test.c`.

Chapter 5

Running a Data Acquisition

GMC_MBS_RUN

5.1 Prerequisites for MBS

If you never have used MBS before, some preparations are needed: You must be familiar with the basic Lynx (UNIX) concepts and commands, and the interrupt handler for CAMAC must be loaded. This is normally done during the boot process.

5.1.1 Account

Ask the MBS group if your account is sufficiently privileged to run MBS.

5.1.2 Login Procedure

During login the group-specific script `/etc/csh.login` is executed (for `tcsh` shell). The directory `/etc` is in the group tree. In the user-specific `.login` script, the MBS specific script `/mbs/prodlogin.com` must be executed. It sets the default to the production version and defines alias names (calling `/mbs/alias_prod.com`):

```
source /mbs/prodlogin.com
news lynx
news daq
```

One should not include the `/bin` directories of MBS in the execution pathlist `PATH`, because all tasks are called from shell by alias names. With alias `deve` one executes `/mbs/devellogin.com` thus switching to the development version. Alias `prod` again switches back to the production version by executing `/mbs/prodlogin.com`. All alias names are redefined accordingly.

5.2 Starting MBS

5.2.1 Steps

To start MBS one must perform the following steps:

1. Prepare the hardware and the on-line programs for the frontend processors.
2. Prepare setup file (see 6.3, page 49).
3. Prepare readout files (see 6.5, page 56) or functions (see 6.6, page 57).
4. Create an environment (see below).
5. Start data taking or analyzing.

5.2.2 Setup

The setup profile describes the hardware and software setup. It must be carefully checked. The parser definition file for the syntax is `/mbs/prod/set/setup.pdf`.

Examples of user setup files (`setup.usf`) can be found in the directories in `/mbs/prod/eva`, a detailed description in 6.3, page 49 for a single-branch setup and 7.2, page 67 for a multi-layer setup.

The first action before starting most of the MBS components is to load this setup file, i.e. to store the values specified in the file into the memory. To do this the `m_util` task must be started:

```
MBS> START TASK M_UTIL
MBS> LOAD SETUP <setup file>
```

Next we start the readout tasks, either the master readout on the master crate (where the collector runs), or the slave readout. Then we load the readout table.

```
MBS> START TASK m_read_meb # or m_read_cam_slav
MBS> LOAD READOUT <readout file>
```

Now we have to set up the trigger module. The values are taken from the setup file:

```
MBS> SET TRIG_MOD
MBS> SHOW TRIG_MOD
```

5.2.3 Readout

For CAMAC there are two methods to specify the readout: profiles or functions. Other subsystems can only be read by user readout functions. The methods can be chosen for each readout independently.

CAMAC Readout Profile

The readout profile (CAMAC readout table) describes the readout. The parser definition file for the syntax is `/mbs/prod/set/readout.pdf`. Examples can be found in the directories in `/mbs/prod/eva`. A detailed description can be found in 6.5, page 56.

Readout by Function

A detailed description of readout functions can be found in 6.6, page 57.

5.2.4 Start Single Environment

Once one has a setup file and a readout table file, one can start up MBS. It is recommended to have a command procedure, i.e. `startup.scom`, to start all tasks needed. The following example shows a startup file for a single-crate system with table readout. The files `setup.usf` and `readout.mrf` must be provided.

```
start task m_util
load setup setup.usf
set trig_mod
start task m_read_meb
load read readout.mrf
start task m_collector
start task m_transport
# optional tasks
start task m_esone_serv
start task m_histogram
start task m_event_serv
start event -noport
# allow TCP client to connect transport
enable tcp
```

`setup.usf` and `readout.mrf` are file names and may be different. When leaving the dispatcher by CTRL Z instead of QUIT, all tasks are stopped. This behavior can be used to shut down the environment. After such a "hard" shutdown, or after a reboot, one should first cleanup:

```
inimbs
mbs
mbs> @startup
```

or

```
remote reset -local
mbs
mbs> @startup
```

where `startup.scom` executes the lines written above.

5.2.5 Start Remote Environments

When there are several nodes, environments must be started on each node. The node names should be in a text file `nodelist.txt`, one per line. For each environment one should have setup, `redaout` and `startup` files prepared. Then the master startup file (`startup.scom`) could look like this:

```
@startup_local
e7_1::@startup_e7_1
e7_2::@startup_e7_2
e7_3::@startup_e7_3
enable tcp
```

This procedure must be executed by the prompter. The first command starts the local environment. The next ones execute the startup procedures of the remote nodes.

```
remote reset
prm
prm> @startup
```

where `startup.scom` executes the lines written above.

5.3 Controlling MBS

A more detailed description of the commands can be found in the MBS command description manual.

5.3.1 Acquisition

Control data taking. First some data taking control commands:

```
MBS> START or STOP or SHOW ACQUISITION  !
MBS> OPEN or CLOSE FILE                 ! Writing to tape/disk
```

A `START ACQUISITION` generates trigger 14 by software. Thus, a user readout function may do some specific data collection for the first event. Similar, a `STOP ACQUISITION` generates software trigger 15. The event with trigger number 15 (last event) is traced through collector and transport to empty the buffer queues. With remote environments, `SHOW ACQUISITION` may output different information depending on the node where it is executed. Some other commands:

```
SHOW TAPE
TYPE EVENT <events> -VERBOSE
SET FLUSHTIME
SHOW RATE
CLEAR DAQ COUNTER
```

Tape Handling

The MBS writes the data in ANSI format to tapes or to disk files. Tapes and files are written in standard GSI format, but in **big endian** byte ordering. Therefore on OpenVMS byte swapping must be done (All GOOSY commands provide byte swapping). Writing to tape requires some additional operations. If the tape is new, it must first be initialized and then mounted. The initialization and the mount should be done by transport commands.

```
MBS> INIT TAPE <label>
MBS> MOUNT TAPE <label>
```

The label of the tape is used for the initialization. After that the tape file will be opened and started like a disk file.

Note: `INIT TAPE` deletes all data on the tape! The `MOUNT TAPE` command may take a long time when the tape already contains data files, because all files are skipped.

To dismount the tape issue the MBS commands:

```
MBS> CLOSE FILE
MBS> DISMOUNT TAPE
```

End of Tape

The transport counts the number of buffers and knows the size of the tape. Normally the file is closed, before the end of tape is reached. When by any reasons the physical end of tape is reached, the current file is closed and the tape is dismounted. The data acquisition is **not stopped**.

Tape Errors

When a tape error occurs, the tape is marked as dismounted and the file is marked as closed in MBS, i.e. no real tape activities are done and the last file remains open. One should remove the tape immediately from the drive. The last file can be read later up to the end. It is not recommended to mount such a tape again for writing.

5.3.2 File Output

Writing list mode data from Transport to a file must be explicitly started and stopped by commands. The acquisition can be started and stopped without affecting the file status. The file can be on disk or on tape. The tape to be used must be initialised and mounted.

When a client, i.e. a GOOSY Transport Manager running under Open VMS, connects via TCP to the MBS transport task the buffer stream is sent to this client **and** to tape, except the TCP channel was enabled by `ENABLE TCP -EXCLUSIVE`. In this case all data are written to tape or to the TCP channel. Files may have a specified size and automatic opening of new files is supported as in GOOSY.

To start file output to a new file and close a file one types

```
MBS> OPEN FILE <file>
MBS> CLOSE FILE
```

The CLOSE FILE command does not stop the acquisition.

File Header

The `OPEN FILE` command writes as first buffer a GSI file header to the file (see 8.2.5, page 80). The header information can be prompted or read from a text file (see description of `OPEN FILE`).

File Names

The file names must follow some conventions to be usable on both, VMS and UNIX:

- Use `a...z`, `0...9` and underscore `_`.
- Do not count on case sensitiveness.
- File name extension should be `.LMD`, where this dot should be the only one.
- The length can be up to 16 characters (ANSI file names).

5.3.3 CAMAC Esone Calls

The utility program `m_esone` provides some commands to execute local CAMAC functions and to test specific CAMAC modules. The commands are:

```
camac cnaif <c> <n> <a> <f> <d> <r>
```

Note that a proper setup file must be loaded, i.e. the same one used for the acquisition! To execute CNAFs from remote nodes, the ESONE module interface provided in GOOSY can be used. The ESONE server `m_esone_serv` must be started. On a GOOSY node, a logical name `CAMAC_BRANCH_0` must be defined:

```
$ DEFINE CAMAC_BRANCH_0 "<node>:ES(<user>)"
```

where `<node>` and `<user>` are specific.

An ESONE library to write ESONE clients is provided. This library is available on VMS, DECunix, Lynx and AIX. See 11, page 117.

`m_esone_serv` uses on CVC a CAMAC address window different from the readout. Thus X and Q responses do not interfere. In the setup file there is a parameter `ESONE_OFF` which must be set to 0x60000 if one wants to use this extra window. When the parameter is set to zero, both, readout and `m_esone_serv` use the same window. On CPUs other than the CVC the parameter must be always zero. **Therefore one should never execute CNAFs on such CPUs when a readout task is running.**

There is another parameter in the setup file which must be set properly to execute CNAFs: That is `PROC_ID` for each crate. The values are:

```
1 = CVC
2 = E6
3 = E7
4 = AEB
5 = CBV
6 = CVI
7 = CAV (Q and X inverted)
```

5.4 On-line Analysis

5.4.1 MBS Histogramming

The MBS provides some tools for simple histogramming. There are commands to handle histograms (CREATE, DELETE, DUMP, SHOW, CLEAR HISTOGRAM). The histograms are allocated in a shared segment. The segment must be created first by command CREATE MEMORY). Other commands are SHOW MEMORY and DELETE MEMORY.

The user may write an analysis function which is linked with the collector. Templates and macros to accumulate histograms are provided.

The histograms can be dumped in GSI standard ASCII files and imported into GOOSY or PAW for further processing. A detailed description is in 10, page 107.

5.4.2 Data Channels from MBS

As can be seen in figure 5.1, page 36 there are many channels to get data out of the MBS. The

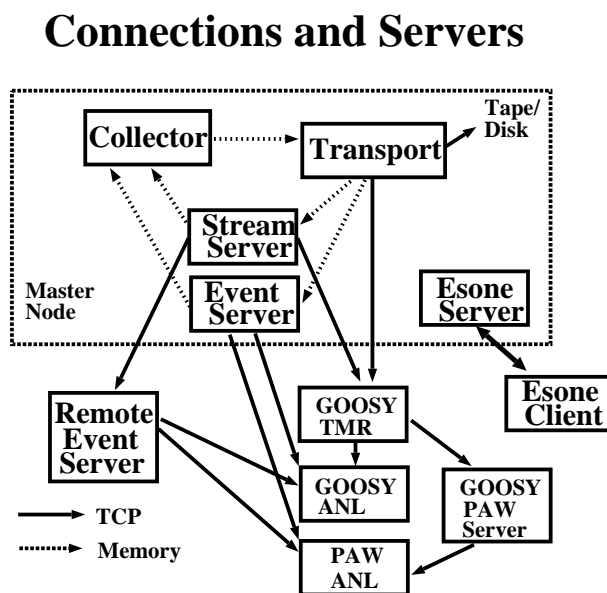

Figure 5.1: Connections and Servers

GSI standard analysis programs GOOSY and PAW can get events from the event server, the remote event server, or the GOOSY-PAW server without changes. Which path to use depends on the requirements concerning the monitoring data rate, the DAQ data rate, and sampling and filtering. We discuss here some examples:

GOOSY without Filters

One should use the GOOSY transport manager TMR and connect GOOSY analysis programs in a standard way. The TMR may connect to the MBS stream server and then get samples controlled by the stream server mode. Or it may connect to the MBS transport server getting all data. In both cases it is recommended to synchronize TMR and analysis by command `SET ACQUIS /SYNC`. This setting does not affect the connection to the MBS, but one should keep in mind that the TMR is waiting in `/SYNC` mode for the analysis programs.

GOOSY and PAW without Filters

One should use the TMR and connect GOOSY analysis programs in a standard way. In addition one starts the GOOSY-PAW server GPS by commands `CREATE PROC GPS $GPS` and `START SERVER channel=3`. The PAW analysis then connects to the GPS. Note that GOOSY analysis and GPS must use different mailbox numbers (channels). Therefore it is recommended to use number three for the GPS and one for the GOOSY analysis (default). But only channel one can be synchronized!

Using the Event Servers

The MBS event server skips streams when there is no request from clients, i.e. it is an asynchronous channel. The remote event server gets data from the MBS stream server which can be set to synchronous or asynchronous mode. The channel between GOOSY or PAW clients and the remote event server is synchronous.

GOOSY and PAW with Filters

The GOOSY analysis can get filtered events from all event servers by command `START INPUT EVENT`. For PAW connections see 9, page 87. Filters are described in 9.10, page 101.

Any Program without Filters

One can use the event I/O library to get easily events into programs. The event input can be the MBS transport, the MBS stream server, or a file. See 9.11, page 106.

A more detailed discussion about on-line analysis programs is in 9, page 87.

5.5 Error Recovery

5.5.1 Task States

The Lynx command `ps -ax` shows the tasks and their states below the S in the headline:

```
C   Currently executing process (will usually be ps itself).
R   Ready to run, but not running.
S   Suspended by a signal (SIGSTOP, SIGTSTP, SIGTTIN, or SIGTTOU).
W   Waiting on a semaphore for some resource.
B   New process awaiting completion of its fork operation.
Z   Zombie waiting to be cleaned up by the init process.
```

Tasks are **Zombies**, if they stopped, but their parent did not cleanup. The MBS tasks are childs of the dispatcher as long as one did not leave it. Once one has left the dispatcher, all tasks are childs of the INIT task (`ppid=1`). The MBS command `STOP TASK -ZOMBIE` cleans up the specified task blocks only in the first case.

Otherwise only the INIT task can do it, but only if it gets the chance. It runs on lower priority than the acquisition. Therefore one should stop the acquisition when there are zombies.

5.5.2 MBS Task Table

The MBS command interface keeps its own task table. This table can be displayed with alias `tasks`. The output may look like:

```
Aktive tasks: read_meb collector transport msg_log dispatch util
  3 /mbs/prod/bin_CVC/m_util           (1)
  4 /mbs/prod/bin_CVC/m_transport      (1)
  5 /mbs/prod/bin_CVC/m_collector      (1)
  6 /mbs/prod/bin_CVC/m_read_meb      (1)
 36 /mbs/prod/bin_CVC/m_dispatch      (1)
 48 test/m_msg_log                    (1)
Inactive tasks: event_serv sbs_mon read_cam_slav esone_serv stream_serv
histogram prompt
```

The number in the first column is the task pid (Lynx). When a task crashed and is still in this task table, one must cleanup everything with `remote reset`. The dispatcher reads this table to get the pids of all known MBS tasks.

5.5.3 Hanging TCP Sockets

When a server having a connection from a client was killed, the socket is not freed immediately. First it is necessary that the client notices that the connection is broken and closes the socket. Then it can take up to a minute until the socket is freed. The sockets in use are shown by Lynx

command `netstat` (see example below). The port numbers used by MBS servers are defined in `/mbs/prod/inc/portnum_def.h`:

```

PORT__TRANSPORT      6000
PORT__ESONE_SERV     6001
PORT__STREAM_SERV    6002
PORT__EVENT_SERV     6003
PORT__PROMPT         6004
PORT__MSG_LOG        6005
PORT__PROMPT_R       6006

```

As long as a socket with one of these port numbers is in state `TIME_WAIT` no server can use this port number again. This state normally disappears after some time (1 min.).

State `FIN_WAIT_2` indicates that a client did not close the socket. In this case the socket remains locked until the client closes the socket. It may take some time until a client gets noticed that a connection is broken because this happens only when it reads or writes from/to the socket. Normally all clients then close the socket, and the socket should change its state to `TIME_WAIT`, and disappear.

5.5.4 Recovery

It may happen that something hangs up. There are some steps one may perform to restart a hanging system before rebooting all nodes:

Try in MBS or PRM to kill all tasks by command `STOP TASK -ALL`. This stops all tasks except the message loggers and dispatchers.

If that does not work, use shell command `remote reset` to kill MBS tasks on remote nodes, cleanup message files and DAQ status (file `<file>` contains one node name per line). Note that the shell command **must** be lowercase:

```

remote show -local      # local node
remote show <node>     # one node
remote show @<file>    # nodes from file <file>
remote reset -local    # local node
remote reset <node>    # one node
remote reset @<file>   # nodes from file <file>

```

The command `remote reset -local` does the same as the following single steps:

1. Use alias `tasks` to get the IDs of tasks which are still running. Kill them.
2. Use `ps` command to see if all MBS tasks are gone.
3. Initialize the control and status segment by alias `inimbs`.
4. Clear the message and command communication by alias `msg_new`.

When there are connections in states other than `ESTABLISHED`, check if all clients closed their connections. Then wait until all connections are OK or gone (may take up to a minute). To get

the `netstat` of all nodes, use command `remote show @<file> -net`. To check if everything is cleaned up execute `remote show -local` or `remote show @<file>` to show MBS tasks, pending messages, or internet connections in state other than ESTABLISHED. It should look like:

```
CVC40 goofy (17) remote show -loc
===== Task table without root tasks! =====
pid  tid  ppid  pgrp  pri  text  stack  data  time  dev  user  S  name
  2 32767  20   20   17   32    12   16    0.21 ttyp0 goofy C /bin/ps
 20 32767  24   20   17   44     8   52    0.28 ttyp0 goofy W /bin/sh
 24 32767  22   24   17  184    16  104    3.79 ttyp0 goofy W /bin/tcsh
 25 32767  20   20   17   48    12   40    0.10 ttyp0 goofy W /bin/grep
11524K free, 940K used (in this display)
===== Task table of MBS daqst =====
Active tasks:
Inactive tasks: read_meb collector transport event_serv msg_log dispatch util
mbs_mon read_cam_slav esone_serv stream_serv histogram prompt
===== Message and command files =====
No pending messages in /dev/msg
No pending messages in /dev/com
===== TCP status =====
Active Internet connections
Proto Recv-Q Send-Q Local Address          Foreign Address        (state)
tcp          0      0 CVC40.gsi.de.telnet   VSCA.gsi.de.2889      ESTABLISHED
=====
```

5.6 Session Example

In the following we show a few examples of MBS sessions. Complete file sets for different hardware setups can be found on directory `/mbs/prod/eva`.

5.6.1 Single CAMAC System

Lines beginning with `#` are comments added here. `CVC40>` is the shell prompt, `mbs>` is the MBS prompt, output from MBS starts with `-CVC40`. All other lines are output from shell commands. Besides that it is the output of a running system, but it is not ment to be replayed.

```
CVC40>
# Initialize:
CVC40> inimbs
created and initalized daq status segment
# Clear communication paths:
CVC40> msg_new
message file /dev/msg removed
command file /dev/com removed
Creating new message file /dev/msg
Creating new command file /dev/com
# start mbs:
CVC40> mbs
mbs> @startup
-CVC40 :msg_log   :09-May-95 19:08:15 Message logger running
-CVC40 :util     :task m_util started
-CVC40 :util     :setup file setup.usf successfully loaded
-CVC40 :read_meb :task m_read_meb started
-CVC40 :read_meb :load master readout file: read.mrf
-CVC40 :read_meb :trigger:-1      setup_file:init.urf
-CVC40 :read_meb :trigger: 1      setup_file:read.urf
-CVC40 :read_meb :trigger:14     setup_file:read14.urf
-CVC40 :read_meb :trigger:15     setup_file:read15.urf
-CVC40 :read_meb :CNAF table successfully loaded
-CVC40 :collector:task m_collector started
-CVC40 :transport:task m_transport started
# event server was not started in command file:
mbs> sta t m_event_serv
-CVC40 :event_ser:task m_event_serv started. Enable by START_EVENT_SERV.
mbs> sta event
-CVC40 :event_ser:Using fixed port 6003
-CVC40 :event_ser:Setup: Buf_str:1/1 M_evt_pstr:ALL/str M_cl:3 Reg_ser:OFF
```

```
-CVC40 :event_ser:Server created: HOST:CVC40 PORT:6003
mbs> sta ac
-CVC40 :util      :start acquisition
-CVC40 :read_meb :found trig type 14 == start acquisition
-CVC40 :read_meb :READ  cnaf: 0x80004000 data: 0x2468
-CVC40 :collector:acquisition running
mbs> sho ac
-CVC40 :util      :-----
-CVC40 :util      :ACQUISITION STATUS at 09-May-95 19:09:02: active tasks:
-CVC40 :util      :m_read_meb m_util m_msg_log m_collector m_transport
-CVC40 :util      :m_event_serv m_dispatch
-CVC40 :util      :Status INITIALIZED, setup LOADED from setup.usf.
-CVC40 :util      :Readout table LOADED from read.mrf, acquisition RUNNING.
-CVC40 :util      :There are 16 streams with 2 buffers a 4096 [b] each.
-CVC40 :util      :Current crate is 0, event builder is CVC.
-CVC40 :util      :-----
-CVC40 :util      :Crate  0: ID=   10, LOCAL  SYNC CVC , subevent slots=  500.
-CVC40 :util      :  trig  1: cvt=  20, fclrt= 10 [usec], max se length=  812 b
-CVC40 :util      :  trig 14: cvt=  20, fclrt= 10 [usec], max se length=   16 b
-CVC40 :util      :  trig 15: cvt=  20, fclrt= 10 [usec], max se length=   16 b
-CVC40 :util      :-----
-CVC40 :util      :Event server delivered 0 events =  0.000 [Mb]
-CVC40 :util      :Histogramming DISABLED
-CVC40 :util      :Name of output device =
-CVC40 :util      :Label = , CLOSED, file = , CLOSED
-CVC40 :util      :          0.000 [MB] written to tape,          0.000 to file
-CVC40 :util      :-----
-CVC40 :util      :Collected:      2.3142 MB,      565 Buffers,      2545 Events.
-CVC40 :util      :Rate           :      566 KB/s,    138 Buffers/s,    625 Events/s
-CVC40 :util      :-----
mbs> ty ev
-CVC40 :transport:==== Buffer    1 ===== 09-May-95 19:09:08.66
-CVC40 :transport:Type=  10    1, Data=2024, Used=2024, Evts=  5, Buf= 1295
-CVC40 :transport:First frag. =0, Last frag.=1, endian=1, Last ev. length= 410
-CVC40 :transport:Event=    5825, Type=  10    1, Words= 410, Trigger=  1
-CVC40 :transport:  SubEv id=  10, Type=  10    1, Words= 402, Subcrate=  0
mbs>
mbs> enab tcp
-CVC40 :transport:starting server thread
-CVC40 :transport:m_transport: wait for connect, port number = 6000
# now a client connects to transport:
-CVC40 :transport:server thread: connected
```

```

# and disconnects (all four messages):
-CVC40 :transport:pipe broken, disconnecting
-CVC40 :transport:closed tcp connection
-CVC40 :transport:ERROR: stc_write
-CVC40 :transport:closed tcp connection

# now a client connects to event server:
-CVC40 :event_ser:I-f_ev_acc_clnt-INFO: Client no:1 accepted.
# and disconnects:
-CVC40 :event_ser:I-f_ev_rmclnt-INFO: client no:1 removed.

# start stream server (stop event server first)
mbs> stop task m_event_serv
-CVC40 :event_ser:/mbs/deve/bin_CVC/m_event_serv exiting.
mbs> sta task m_stream_serv
mbs>
-CVC40 :stream_se:task m_stream_serv started
mbs>
mbs> quit
CVC40> tasks
Aktive tasks: read_meb collector transport msg_log util stream_serv

    4 /mbs/deve/bin_CVC/m_read_meb          (1)
    5 /mbs/deve/bin_CVC/m_util              (1)
    6 /mbs/deve/bin_CVC/m_msg_log          (1)
    7 /mbs/deve/bin_CVC/m_collector        (1)
    8 /mbs/deve/bin_CVC/m_transport        (1)
   10 /mbs/deve/bin_CVC/m_stream_serv      (1)
Inactive tasks: event_serv dispatch mbs_mon read_cam_slav esone_serv
histogram prompt
CVC40> rate -t1
Interval: 1 s. 2 buffers a 4096 b per stream.

109622 Bufs,      493301 Evts,    0. Bufs/s,    0. KB/s,    0. Evts/s
109768 Bufs,      493961 Evts,   143 Bufs/s,   586 KB/s,   647 Evts/s
109911 Bufs,      494602 Evts,   139 Bufs/s,   569 KB/s,   622 Evts/s
110050 Bufs,      495227 Evts,   136 Bufs/s,   558 KB/s,   613 Evts/s
^C
CVC40> mbs
mbs> sho task
-CVC40 :dispatch :Task table of MBS:
-CVC40 :dispatch :  m_read_meb      /mbs/deve/bin_CVC/m_read_meb      id 4 (4)

```

```
-CVC40 :dispatch : m_util          /mbs/deve/bin_CVC/m_util          id 5 (5)
-CVC40 :dispatch : m_msg_log       /mbs/deve/bin_CVC/m_msg_log       id 6 (-1)
-CVC40 :dispatch : m_collector     /mbs/deve/bin_CVC/m_collector     id 7 (7)
-CVC40 :dispatch : m_transport    /mbs/deve/bin_CVC/m_transport    id 8 (8)
-CVC40 :dispatch : m_stream_serv  /mbs/deve/bin_CVC/m_stream_serv  id 10 (10)
-CVC40 :dispatch : m_dispatch     /mbs/deve/bin_CVC/m_dispatch     id 16 (16)
-CVC40 :dispatch :Task table of dispatcher:
-CVC40 :dispatch : m_dispatch     started
-CVC40 :dispatch : m_read_meb     started
-CVC40 :dispatch : m_collector    started
-CVC40 :dispatch : m_util        started
-CVC40 :dispatch : m_transport    started
-CVC40 :dispatch : m_stream_serv  started
-CVC40 :dispatch : m_msg_log     detached
-CVC40 :dispatch :Get full commands by ?? or ??? or get arguments by <command> ?
#
# Now shut down
#
mbs> stop ac
-CVC40 :util          :stop acquisition
-CVC40 :read_meb     :found trig type 15 == stop acquisition
-CVC40 :collector:acquisition NOT running
mbs> stop task -all
-CVC40 :read_meb     :/mbs/deve/bin_CVC/m_read_meb exiting..
-CVC40 :collector:/mbs/deve/bin_CVC/m_collector exiting..
-CVC40 :transport:/mbs/deve/bin_CVC/m_transport exiting
-CVC40 :util        :/mbs/deve/bin_CVC/m_util exiting..
# stop m_stream_serv:
mbs> stop t m_stream_serv
-CVC40 :stream_se:/mbs/deve/bin_CVC/m_stream_serv exiting
mbs> quit
# kill message logger (task id from above)
CVC40> kill 6
# check if all tasks are gone:
CVC40> tasks
Aktive tasks:
Inactive tasks: read_meb collector transport event_serv msg_log dispatch util
mbs_mon read_cam_slav esone_serv stream_serv histogram prompt
# Clear communication paths:
CVC40> msg_new
message file /dev/msg removed
command file /dev/com removed
```

```
Creating new message file /dev/msg
Creating new command file /dev/com
# Initialize:
CVC40> inimbs
created and initalized daq status segment
CVC40>
CVC40>
```

Chapter 6

Readout Control

GMC_MBS_READ

6.1 Readout Tasks

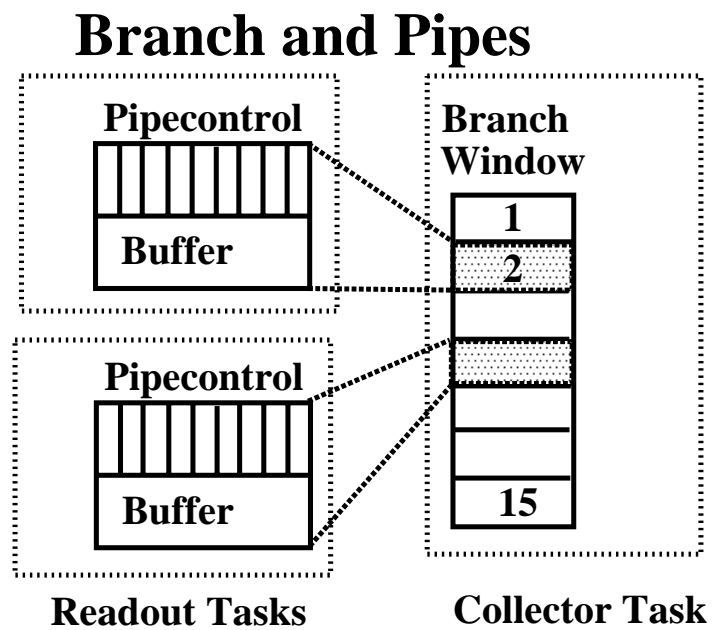

Figure 6.1: Branch and Pipes

All hardware modules in a MBS system are read by the tasks `m_read_meb` and/or `m_read_cam_slav`

and/or `m_read_aeb_slave`.

The `m_read_meb` task runs on the branch master controller and reads possibly its local and/or its remote crates equipped with non intelligent controllers (CAMAC: CBV, FASTBUS: SMI). `m_read_meb` runs on the CVC (CAMAC), E6 and E7 (VME). `m_read_cam_slav` runs only on CVCs acting as intelligent CAMAC slave controllers and it reads only its local crate. `m_read_aeb_slave` runs only on AEBs acting as intelligent FASTBUS slave controllers and it reads only its local crate.

All readout tasks described above write their data into subevent pipes. For each crate a subevent with a GSI subevent header is written into the pipe(s). The subevent pipes may reside locally in the controller memory but they could also be placed into a remote memory module which is accessible in an address mapped mode. The pipes are read, formatted into events into GSI buffers by the collector task which runs on the branch master.

All readout tasks need a corresponding GSI trigger module to start the (event) readout.

`m_read_meb` may be triggered in an interrupt or in a polling mode. If polling mode is selected the trigger module must not necessarily be placed in the same crate. It can be anywhere, where `m_read_meb` has address mapped access to its trigger module registers. In interrupt mode it must be in its local crate.

`m_read_cam_slav` and `m_read_aeb_slav` are always triggered in polling mode. The trigger module must therefore be in the local crate.

Two methods of readout specification are provided. If the hardware modules to be read out are pure CAMAC the readout can be specified in simple readout tables. The readout itself is then performed with zero suppression. Generally the user may write user readout functions to read out any type of module in any type of crate. No mixture between table readout and user readout function is possible.

A complete single-branch system (and single-crate) setup must be specified in a single ASCII file.

6.2 Readout Software Overview

Specification of the hard and software configuration of a single-crate or single-branch data acquisition system is kept in a single ASCII file provided by the user. It has the name extension `.usf`, which stands for "user setup file". A convenient name is `setup.usf`.

The system is furthermore specified by running the appropriate tasks, especially the readout task, on the intelligent controllers. This will be done in startup command procedures ("start.scom") at system startup. On the branch master controller the task `m_read_meb` has to be started, but only if any crate has to be read out by it. On CVCs working as slave controllers the task `m_read_cam_slav` and on AEB-EBIs `m_read_aeb_slave` must be started.

Two methods for specifying the readout of hardware modules are provided. The easy but less versatile method uses user written readout tables (ASCII files), which must be loaded by command. This method is only possible for systems with pure CAMAC readout. The second method provides an interface for users to write their own readout function in the program language

Buffer Streams

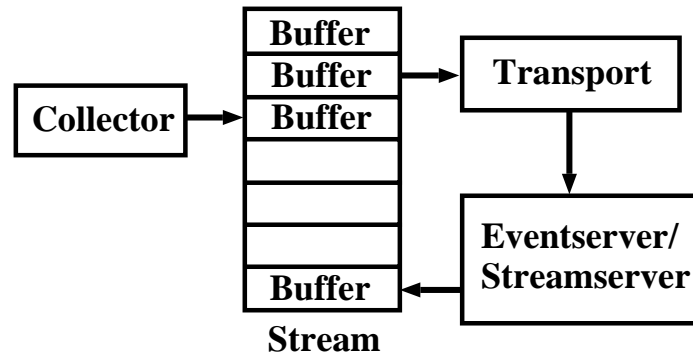

Figure 6.2: Buffers and Streams

C. There is practically no limitation on actions in this functions, so the user gets the full flexibility but also the full responsibility for a correct working readout. No mixture between these two methods inside a single branch is allowed. In both methods a crate corresponds to a subevent, which means that the readout tasks produce a subevent for each crate with an appropriate subevent header.

6.3 Single-Branch Setup Specification

As mentioned above the system specification is done in an ASCII file. This file (`setup.usf`) will be parsed, checked and the setup quantities loaded into each controller (processor) memory at an early stage of system startup. All running tasks access this memory module to get the system configuration information.

The best way to produce a setup file is to copy a template file and change all entries according to the following explanations. In the directory `/mbs/prod/exa` several subdirectories will be found, which contain complete working environments for various data acquisition setups. Each of them contains a valid `setup.usf` file. The names of these directories describe already the kind of setup.

The following description will follow the sequence in the template files. All values for parameters not mentioned should not be changed. For more information on those see `s_setup.h` on `/mbs/prod/inc/`. Behind each parameter in the user setup file follows a number which could also be an array of numbers, where the index of the array indicates (up to now) always the crate number.

NOTE: If a parameter requires an array of numbers (for crate 0-15), values for all array elements must be specified, regardless if a crate is used or not. This is required by the parser

syntax.

All these values are meaningless as long as the values given for the Readout Flag parameter `RD_FLG` - which one can think of as the master flag - are zero. Valid values for the `RD_FLG` parameter as a function of the crate number are:

- 0** : Nothing should be done with this crate.
- 1** : The branch master must read out this crate.
- 2** : A local intelligent controller reads this crate.

6.3.1 Setup File: Parameters

The syntax is found in 8.1.1, page 74. Now follows the explanation of the relevant parameters in the setup file:

MASTER : Indicates the type of the branch master:

- 1 : CVC
- 2 : E6
- 3 : E7

REM_MEM_BASE : (array) Physical base address for a shared segment inside a remote subevent pipe will be seen by the branch master. On VSB systems this must be `0xF0000000` for E6 and E7 and `0x08000000` for a CVC as branch master.

REM_MEM_OFF : (array) Offset to a shared segment. On VSB based systems this must be `crate nr. * 0x200000`. `REM_MEM_BASE + REM_MEM_OFF` define the physical start address of a remote subevent pipe.

REM_MEM_LEN : (array) Length of a shared segment with physical base `REM_MEM_BASE + REM_MEM_OFF` and therefore length of the remote pipe (in bytes).

The memory on the CVC can be accessed via VSB only from the beginning of the RAM with base address `0x100000` up to about 500 kB. But normally this is also the base address of the LynxOS (UNIX) kernel. As a compromise the kernel base address has been moved to `0x140000`, leaving an address window from `0x100000` to `0x140000` free for the subevent readout pipe. For the AEB-EBI fastbus controller the subevent readout pipe is placed into the EBI memory with base address `0x1000000` seen from the AEB.

REM_CAM_BASE : (array) Physical base address to a shared segment for executing remote CAMAC from the branch master via a CBV. On VSB systems this must be `0xF0180000` for E6 and E7 and `0x08180000` for a CVC as a branch master.

REM_CAM_OFF : (array) Offset to a shared segment. On VSB based systems this must be `crate nr. * 0x200000`. `REM_CAM_BASE + REM_CAM_OFF` define the physical start address of a remote CAMAC segment. These base addresses are passed as virtual pointers into the user readout function.

REM_CAM_LEN : (array) Length of a shared segment with physical base **REM_CAM_BASE** + **REM_CAM_OFF** and therefore length of the remote CAMAC segment. **REM_MEM_LEN** = 0x50000 is enough to cover the complete CAMAC space of one remote crate.

LOC_ESONE_BASE : This setup parameter is used only if the task **m_esone_serv** is running on a branch master CVC. In this case it must be set to 0x4180000.

REM_ESONE_BASE : This setup parameter specifies the address window to access remote CAMAC on slave crate controllers connected via VSB from a VSB branch master. The VSB master could be any processor type. For a CVC this parameter must be set to 0x8180000, for an E6 and E7 it must be set to 0xf0180000.

ESONE_OFF : Principally, CAMAC cnafs can be executed from the **m_esone_serv** task at the same time a readout is running and accessing CAMAC. Then the problem arises that it is not possible to distinguish if CAMAC X and Q belongs to the readout or ESONE cnafs. This problem has been circumvented only on CVCs, regardless if VSB master or slave, by implementing a second CAMAC address window reserved for ESONE cnafs. This window is placed 0x50000 above the normal readout window and this is the value for this parameter. It implies that ESONE cnafs should not be executed on E6 or E7 (master) and CBVs (slave) when a readout is running.

Note: The parameter **CONTROLLER_ID** described below must also be set to the right value to get correct X and Q from ESONE calls.

LOC_MEM_BASE : (array) These are the hardware base addresses where each intelligent controller in a single branch is supposed to access its hardware modules. It could be for example the local CAMAC base or the extended VME base. This base address is passed as a virtual pointer into the user readout function.

LOC_MEM_LEN : (array) Length of the address window, with base **LOC_MEM_BASE**.

LOC_PIPE_BASE : (array) Parameter to specify the base address of a shared segment inside the subevent pipe will be placed. Must be specified for each intelligent controller in a single branch. This parameter is always the local address on a controller.

PIPE_OFF : (array) The start address of a subevent pipe is specified with **LOC_PIPE_BASE** + **PIPE_OFF**.

PIPE_SEG_LEN : (array) Total length of the subevent pipe on each intelligent controller (in bytes).

PIPE_LEN : (array) Maximum number of subevents which can be stored in a subevent pipe before the pipe blocks.

The structure of the subevent readout pipe is fully specified by **PIPE_SEG_LEN** and **PIPE_LEN**: The first 20 bytes at the beginning of the pipe are reserved for a general pipe control structure. Then follow **PIPE_LEN** subevent control structures, 20 bytes each. The remaining

space is divided into two longword aligned data buffers. The values for `PIPE_SEG_LEN` and `PIPE_LEN` should be specified so that on average the data for `PIPE_LEN` subevents fit into the two data buffers. Note that subevents cannot span over buffer boundaries. It must be ensured that the largest subevent is not bigger than the size of one data buffer, i.e. $(PIPE_SEG_LEN - 20 * (PIPE_LEN + 1)) / 2$. The subevent data in the pipe buffers **includes** the subevent header(s).

MAX_SE_LEN_TRIGTYP1 ... MAX_SE_LEN_TRIGTYP15 : (arrays) These 15 parameters are optional and must **ONLY** be specified if user readout functions are used as readout method. For table readout they can be omitted. They specify the maximum size of a subevent in number of bytes as a function of crate number and trigger type. For each trigger type which possibly will be fed into the trigger module the appropriate `MAX_SE_LEN_TRIGTYPX` must be found in the setup file.

RD_FLG : (array)

- 0 : Crate shall not be read,
- 1 : Crate shall be read by master event builder,
- 2 : Crate shall be read by slave controller

RD_TYP : Readout method:

- 0 : table readout (CAMAC only)
- 1 : user readout functions

CONTROLLER_ID : (array) Type of crate controller:

- 1 : CVC
- 2 : E6
- 3 : E7
- 4 : AEB-EBI
- 5 : CBV
- 6 : CVI
- 7 : CAV

A correct `CONTROLLER_ID` is also required by the esone server task running on the branch master.

SY_ASY_FLG : (array) Each crate (subevent) can be set as a synchronous or an asynchronous crate. Synchronous means that the collector will wait for this subevent to be ready. Asynchronous means that the subevent will be ignored if it was not ready at the time the collector task is scanning to build the event. `SY_ASY_FLG = 0` synchronous, `SY_ASY_FLG = 1` asynchronous.

COL_MODE : Specifies the output mode of the collector task running on the branch master.

- 0** : (Standard mode) the collector collects subevents from the various subevent pipes and formats events into buffer streams and passes the streams to the transport task.
- 1** : The collector collects subevents from the various subevent pipes but no event formatting

will be done. Instead all collected subevents are written into a single output pipe. This output pipe will itself be read by a collector of a higher layer in a multi-layer multi-branch system. This mode requires that `ML_PIPE_BASE_ADDR`, `ML_PIPE_SEG_LEN` and `ML_PIPE_LEN` to be specified (see explanation below).

2 : If a single-branch system consists of only one intelligent processor and is itself a component of a multi-layer multi-branch system it can be very useful that no collector task runs at all in this single branch. The subevents are written by the `m_read_meb` task into the subevent pipe, which is read by a next layer collector.

3 : this mode includes mode 0 and 1. It makes it possible to pass data to output devices on any node with a running collector.

ML_PIPE_BASE_ADDR : Base address of a collector output pipe. Only requested if `COL_MODE` is either 1 or 3.

ML_PIPE_SEG_LEN : Length of the collector output pipe (in bytes). Only requested if `COL_MODE` is either 1 or 3.

ML_PIPE_LEN : Number of subevent/fragment slots of the collector output pipe. Only requested if `COL_MODE` is either 1 or 3.

NOTE: The structure of the collector output pipe is actually the same as the subevent pipes written by the readout tasks. The collector scans for all pipes it has to read and writes all subevents consecutively into the output pipe.

COL_RETRY : Number of scans for ready pipes the collector task performs before giving other tasks the chance to execute by system call `yield`.

MEB_TRIG_MODE : This parameter can be used to specify special modes for the trigger module serving the `m_read_meb` task. Modes are:

0 (standard) = local interrupt (CAMAC LAM, VME irq).

For the next special modes the setup parameters `SPECIAL_MEB_TRIG_BASE` and `SPECIAL_MEB_TRIG_TYPE` described below must specify the base address and trigger module type, respectively.

1 (special) = local interrupt (CAMAC LAM, VME irq), but non-standard base address of the triggermodule.

2 (special) = remote VSB interrupt, i.e. trigger module is not located inside the local crate (not yet implemented).

3 (special) = no interrupt, but polling mode. In this mode the readout task polls a bit in the trigger status register. No other task can execute until the Lynx time slice is over and the scheduler switches execution to another task.

In all modes the fast clear and conversion time will be taken from parameters `TRIG_FCT[0]` and `TRIG_CVT[0]`.

SPECIAL_MEB_TRIG_TYPE : Must be specified when **MEB_TRIG_MODE** is not set to zero.

- 1 : CAMAC trigger module
- 2 : VME trigger module
- 3 : FASTBUS trigger module

SPECIAL_MEB_TRIG_BASE : Must be specified when **MEB_TRIG_MODE** is not set to zero.

NOTE: If the trigger module is in a remote (VSB) CAMAC crate, the CAMAC VSB base address must be specified. For example 0xF0580000 for a CAMAC trigger module in crate 2 serving **m_read_meb** running on an E7 in a VME crate.

TRIG_STAT_NR : (array) Station number of trigger module. Set always to 1 and in CAMAC crates it must be housed in station number 1.

TRIG_FCT : (array) Fast clear time for trigger modules. The number specified has to be in the range of 20-65535 and must be smaller than **TRIG_CVT**. The fast clear time is set to: 100 nanoseconds * **TRIG_FCT**.

TRIG_CVT : (array) Trigger conversion time. The number specified has to be in the range of 20-65535. The conversion time is set to: 100 nanoseconds * **TRIG_CVT**.

The range for **TRIG_FCT** and **TRIG_CVT** is between 2 μ sec and 6.5 msec. Both numbers are written into the trigger module during initialisation with the command **set trig_mod**.

Immediately after a trigger signal is detected by a trigger module the conversion time is started. After it has elapsed a LAM/IRQ is sent into the crate controller and the readout procedure is started. The conversion time is intended to allow for conversion and digitization of hardware modules and adds deadtime.

Therefore the conversion time must be set to the maximum time required for all modules to be read by the task serving that trigger. I.e. in case the trigger module triggers the readout task on the branch master (**m_read_meb**, crate number = 0) the conversion time must be set to the maximum time required for any module in all crates to be read by **m_read_meb**.

A time delay between the arrival of an interrupt and the first readout action executed by the readout task of at least 140 μ s on a CVC and 40 μ s on an E7 has been measured.

This delay was found for the master readout task (**m_read_meb**) working in interrupt mode. It operates in a multitasking environment and the delay is the time the operating system needs to inform a user task on an external interrupt. On a CVC working as a slave controller the delay is much smaller, since in this case the mechanism to catch triggers is polling, which is much faster (shorter than 5 μ s).

On CAMAC CVC single-crate systems, the user therefore can save deadtime by taking the interrupt delay into account calculating the conversion time. I.e. if the needed real conversion time is smaller than 140 μ s the trigger conversion time may be set to the minimum value of 2 μ s (**TRIG_CVT** = 20).

EV_BUF_LEN : Length in bytes of one buffer, multiples of 1024 up to 32768 are allowed.

N_EV_BUF : Number of buffers contained in one stream.

N_STREAM : Number of streams.

EV_BUF_LEN, **N_EV_BUF**, and **N_STREAM** have nothing to do with the readout, they are described for completeness. If there are no special requirements a reasonable choice would be: **EV_BUF_LEN** = 0x4000 = 16384, **N_EV_BUF** = 8, **N_STREAM** = 8. This specifies an event buffer space of 8 buffers times 8 streams, thus in total 1 Mbytes of space. If users want to have a larger event buffer space, it must be checked if that amount of memory is free after all data acquisition tasks have been started.

For the exact meaning of the remaining parameters one should see 8.2, page 79. The values set for these will appear in the event and subevent headers and are important for analysis programmes, but not for the data acquisition itself.

EVT_TYP_SY : Event type for events. Strongly recommended is **EVT_TYP_SY** = 10.

EVT_SUBTYP_SY : Subevent type for events.

SE_TYP (array): Subevent type. For CAMAC crate subevents **SE_TYP** = 10 is recommended.

SE_SUBTYP (array): Subevent subtype.

SE_CONTROL : This parameter can be used freely by the user, but it is strongly recommended to put a branch identifier in multi-branch systems at this place to be able to identify branches in analysis programs.

SE_PROCID : Subevent processor identifier which can be set freely by the user.

NOTE: Don't mix up "subevent type" and "event subtype".

6.4 Readout Specification

Both readout methods, table readout and user readout proceed in the following way: After the command **START ACQUISITION** the init function is called which executes actions, but no data will be moved into the event stream. This is intended for proper initialization of hardware modules. Then a software trigger with type 14 is send to the trigger module, which starts an event readout sequence. The first event after **START ACQUISITION** is always of trigger type 14. After that the system waits for hardware triggers and for each occurrence an event will be built. The **STOP ACQUISITION** command initiates a software trigger of type 15, which also starts a normal event readout sequence. Thus the last event in the data will always be trigger type 15.

6.5 Table Readout

Syntax see also 8.1.3, page 77. Table readout is only possible in systems which include only CAMAC modules. It is specified in two steps. First, a master readout file (i.e. `read.mrf`) which specifies the filenames for the init (i.e. `init.urf`) and readout tables (i.e. `readxy.urf`) must be provided. Second, the init and readout tables (`*.urf` files), which define the CAMAC actions must also be created.

Once the files have been created they can be loaded into shared memory tables with the command `LOAD READOUT fn.mrf` when the readout task is running. This command can be executed with different master readout files as many times as the user likes to do. The last loaded, will come into operation.

6.5.1 Table Readout Parameters

In the master readout file one can specify the following facilities, i.e. lines with a certain syntax identified by a name (facility). The provided parameters are written in brackets.

INITFILE : `file=<>`. Specification of init file.

READFILE : `file=<>`, `trigger=<>`. Specification of readout files for each trigger.

In the init file one can specify the facility:

CAMINIT : `crate=<>`, `nstation=<>`, `address=<>`, `function=<>`,
optional `data=<>` and `repetition=<>`. CNAF specification.

In the readout file one can specify the facility:

CAMREAD : `crate=<>`, `nstation=<>`, `address=<>`, `function=<>`,
optional `repetition=<>`. CNAF specification.

The `<>` have to be replaced by the appropriate values.

6.5.2 Table Readout Subevents

Table readout performs a zero suppression. For each CNAF resulting a non zero value there are two 16 bit words in the subevent. The first one is the value, the second one the current number of the CNAF in the file (big endian!).

6.5.3 Table Readout Example

Example (`/mbs/prod/exa/cvc_camac_single_crate_table_read/read.mrf`)

```
INITFILE:   file="init.urf"  
READFILE:  file="read1.urf", trigger=1  
READFILE:  file="read1.urf", trigger=3  
READFILE:  file="read14.urf", trigger=14  
READFILE:  file="read15.urf", trigger=15
```

The example shows that for each trigger type a file must be provided, the same files are allowed for different trigger types. If the init file is not specified this results simply in no action. Also if trigger types occur during data taking which have no corresponding readout file a subevent without data will be produced and found in the event. The extensions of the files must be .urf for User Readout File.

Example (/mbs/prod/exa/cvc_camac_single_crate_table_read/init.urf)

```
CAMINIT:   c= 0,   n= 30,   a= 9,   f= 24  
CAMINIT:   c= 0,   n= 2,   a= 0,   f= 16,   d= 0x2468  
CAMINIT:   c= 0,   n= 2,   a= 0,   f= 0,   rep=3  
#  
CAMINIT:   c= 1,   n= 30,   a= 9,   f= 24  
CAMINIT:   c= 1,   n= 2,   a= 0,   f= 16,   d= 0x1111  
CAMINIT:   c= 1,   n= 2,   a= 0,   f= 0  
#  
CAMINIT:   c= 5,   n= 30,   a= 9,   f= 24  
CAMINIT:   c= 5,   n= 2,   a= 0,   f= 16,   d= 0x5555  
CAMINIT:   c= 5,   n= 2,   a= 0,   f= 0
```

It is good habit to include the CAMAC action shown in the example `CAMINIT: c= 0, n= 30, a= 9, f= 24` for each crate, since this removes the CAMAC inhibit, which is set after power on. Most commercial modules require this to be accessible on the CAMAC bus. Both, CAMAC read and write functions are allowed in the init part.

Example (/mbs/prod/exa/cvc_camac_single_crate_table_read/read1.urf), for trigger type 1.

```
CAMREAD:   c= 0,   n= 2,   a= 0,   f= 0,   rep=100  
CAMREAD:   c= 1,   n= 2,   a= 0,   f= 0,   rep=5  
CAMREAD:   c= 5,   n= 2,   a= 0,   f= 0,   rep=1
```

Due to performance considerations only CAMAC **read** functions are allowed in the readout part.

In the init and readout files all actions can be put, regardless if the readout will be executed by a slave controller or the branch master. CAMAC actions (CNAFs) specified for crates not read out are not loaded if the setup parameter `RD_FLG` is 0 for these crates.

6.6 User Function Readout

There are two different methods to create user readout functions. The first one uses macros to read out hardware. It is intended for users with no knowledge of the C programming language.

The second method uses static pointers. If the user wants to produce the fastest possible readout the second method has to be chosen, since the simplicity of the first one is paid by a slightly lower performance readout. The best way to make a user readout would be to copy a template directory and make changes in the template `f_user.c` file. In the directory `/mbs/prod/exa` several subdirectories will be found, which contain complete working environments for various data acquisition setups. Each of them contains a valid `f_user.c` file. The names of these directories describe already the kind of setup. The readout task is then compiled and linked by executing the "make" command. The necessary Makefile is also placed in this directory.

NOTE: It is absolutely vital that the maximum subevent size specified in the setup file (`MAX_SE_LEN_TRIGTYP1 ... MAX_SE_LEN_TRIGTYP15`) is not exceeded in the user readout function. The `f_user.c` template file contains the functions `f_user_init` and `f_user_readout`. The calling is the same for both methods mentioned above.

```
int f_user_init (unsigned char  bh_crate_nr,
                long           *pl_loc_hwacc,
                long           *pl_rem_cam,
                long           *pl_stat)
```

bh_crate_nr: Crate number

pl_loc_hwacc: Base pointer for execution of local crate readout
(master- or slave readout task).

pl_rem_cam: Array of base pointers for execution of remote CAMAC actions via VSB for
crate number = `bh_crate_nr` (master readout task `m_read_meb`).

pl_stat: Pointer for status return (not used yet).

`f_user_init` is called once for each crate readout after the `START ACQUISITION` command.

```
int f_user_readout (unsigned char  bh_trig_typ,
                   unsigned char  bh_crate_nr,
                   register long   *pl_loc_hwacc,
                   register long   *pl_rem_cam,
                   long            *pl_dat,
                   s_veshe        *ps_veshe,
                   long            *l_se_read_len,
                   long            *l_read_stat)
```

bh_trig_typ: Trigger type

bh_crate_nr: Crate number

pl_loc_hwacc: Base pointer for execution of local crate actions
(master- or slave readout task).

pl_rem_cam: Array of base pointer for execution of remote CAMAC actions via VSB for
crate number = `bh_crate_nr` (master readout task).

pl_dat: Pointer where to write data.
ps_veshe: Pointer to access and manipulate subevent header.
l_se_read_len: Pointer to return total subevent length in bytes.
l_read_stat: Pointer for status return (not used yet).

For each occurrence of a trigger the `f_user_readout` function is called once for each crate.

The same object file compiled from functions `f_user_init` and `f_user_readout` will be linked into the master- and slave readout tasks. The data acquisition system takes into account for which crate number the readout functions are called. The template files show one possible procedure to distinguish actions for different crate numbers and trigger types with a C "switch" statement. This method allows the complete init/readout actions to be kept in a single file, regardless of crate number, trigger type, master or slave readout task. Similarly, init/readout actions of crates or trigger types not used for a specific run can be left in the code which saves unnecessary compilation time.

6.6.1 Macro Readout Method

One may use convenient readout macros in `f_user_init` and/or `f_user_readout`. Five macros have been prepared and are found in `read_mac.h` in the `/mbs/prod/exa/cvc_camac_single_crate_macro_read` template directory. Each macro represents a CAMAC action. In macros that write data into the event stream care is already taken for incrementing the subevent length and the pointer `pl_dat`, were the data has to be written. The user is free to create further macros.

The syntax and parameters to pass for CAMAC macros are:

CNAF_RD_INIT(c,n,a,f,offset) : Reads one CAMAC word from a module but writes nothing into the subevent data.

CNAF_RD(c,n,a,f,offset) : Reads one CAMAC word and writes it as a long word into the subevent data.

CNAF_RD_0SUP(c,n,a,f,offset) : Reads one CAMAC word, checks if CAMAC data is zero, if not writes 16 bit of data into bit 16-31 and an incremented channel number into bits 0-15 of a long word and writes it into the subevent. If the CAMAC data value is 0 only the channel number is increased. This is actually the same action as implemented for the standard table readout.

CNAF_TOUCH(c,n,a,f,offset) : Dataless CAMAC function.

CNAF_WR(c,n,a,f,data,offset) : CAMAC write action.

c = crate number,
n = station number,
a = subaddress,
f = function

data = data to write into CAMAC modules.

offset = `pl_loc_hwacc` if crate is the local of the intelligent crate controller were the readout task runs (`m_read_meb` or `m_read_cam_slav`).

offset = `pl_rem_cam[crate nr.]` if crate is not local to the crate controller, which reads that crate. This can only be the master readout task (`m_read_meb`) which reads that remote crate via VSB and remote CAMAC actions. `pl_loc_hwacc` and `pl_rem_cam` are passed into the function.

6.6.2 Static Pointer Readout Method

The structure of the `f_user.c` file must be as following. Before the code of the three functions `f_user_get_virt_ptr`, `f_user_init` and `f_user_readout` all hardware addresses (CNAFs, VME) accessed during the init phase and readout have to be defined as static volatile (long) pointers. Arrays or structures of pointers are of course possible.

In the function `f_ut_get_virt_ptr` these pointers have to be constructed as virtual pointers, that means an offset has to be added to the hardware addresses. The necessary offsets are passed as parameters with the function and are known only at runtime. The same rules holds like in the macro method: Crates read out by local intelligent controllers have an offset `pl_loc_hwacc`. For non-local crates read out by the master readout task, the offset is `pl_rem_cam[crate nr.]`. To create virtual pointers to access CAMAC a macro CNAF is coded in the very beginning of `f_user.c`. The call

```
virt_ptr = CNAF(c,n,a,f,offset);
```

creates the virtual pointer for the use in the `f_user_init` and `f_user_readout` function. In the `f_user_readout` function the user now has to care for the correct incrementing of the `pl_dat` pointer when writing data into the subevent. A typical operation to read from hardware and write into the subevent would be

```
*pl_dat++ = *virtual_ptr;
```

At the end the correct subevent length in bytes has to be returned:

```
*l_se_read_len = length_in_bytes;
```

For users familiar with the LynxOS operating system there is also the possibility to create shared memory segments in any hardware address window in the `f_user_init` function with the `smem_create` library call. The return value of this function would be the virtual pointer (offset) to the base of the specified hardware adress window. In that way it is possible to access any address based hardware which is connected to the specific controller.

6.6.3 Changing Subevent Headers

Changing or introducing more (private) subevent headers can be done in the same way for both user readout function methods.

In front of each subevent data part filled by the readout function, a standard GSI subevent header is added by the system (see 8.2.9, `pagerefddata-subevent`). It is up to the user to add

information behind this header by writing at the very beginning of each readout onto `pl_dat` (`*pl_dat++`).

The structure of this header is found in `/mbs/prod/inc/s_veshe.h` (see 8.2.9, page 83). Some quantities in the subevent header have been already specified in the setup file, some have to be calculated at run time like the subevent length. The user gets access to the subevent header with the pointer `ps_veshe` passed into the `f_user_readout` function. If the function writes a value into `ps_veshe→l_dlen`, the system assumes that the user took full control over the subevent header and does not change it any more. By this method the readout function can overwrite the values in the subevent header, i.e. type and subtype. If `ps_veshe→l_dlen` is not changed, the system sets it using the parameter `l_se_read_len` which **must** be correctly set by the readout function anyway.

As long as the readout function does not split its data buffer into several subevents `ps_veshe→l_dlen` must be `l_se_read_len/2 + 2` if set.

It is possible to generate e.g. two subevents instead of one for one event in one readout function. In that case `ps_veshe→l_dlen` must be set to `<length of 1st subevent>/2+2`. Behind `<length of 1st subevent>` bytes in the data buffer there must be the second subevent header followed by data. This subevent header must be filled properly. `l_se_read_len/2 + 2` still must return the total length of the data buffer.

6.6.4 User Readout Functions on AEB-EBI under OS-9

The AEB-EBI runs as an intelligent crate controller only under the operating system OS-9. It can be used only as a slave controller running the readout task `m_read_aeb_slave`. The hardware readout is executed by FASTBUS function calls which invoke actions on the FASTBUS engine of the AEB. Therefore the `f_user.c` template, as found on an AEB in the directory `/mbs/prod/src` contains again the functions `f_user_init` and `f_user_readout` but with a reduced set of arguments passed. On the AEBs, directory `/mbs/prod/src` is mounted via NFS to a different file system than on Lynx nodes. Readout actions for all AEBs used in a data acquisition system can be put in a single file like it is done for the LynxOS controllers.

```
int f_user_init (unsigned char  bh_crate_nr,
                long           *pl_stat)
```

bh_crate_nr: Crate number

pl_stat: Pointer for status return (not used yet).

```
int f_user_readout (unsigned char  bh_trig_typ,
                   unsigned char  bh_crate_nr,
                   long            *pl_dat,
                   s_veshe        *ps_veshe,
                   long            *l_se_read_len,
                   long            *l_read_stat)
```

bh_trig_typ: Trigger type
bh_crate_nr: Crate number
pl_dat: Pointer to write data
ps_veshe: Pointer to access and manipulate subevent header.
l_se_read_len: Pointer to return total subevent length in bytes.
l_read_stat: Pointer for status return (not used yet).

The same rules are valid for `pl_dat`, `l_se_read_len` and the change of subevent headers as described in section in the previous section.

6.7 Running a System with User Readout Functions

To start and stop a system a sequence of commands must be executed after the command dispatcher has been started (`mbs`). This can be simplified by collecting these commands in a command procedure file with an extension `.scm` and execute it with `@filename`. In the following it is assumed that the dispatcher was called in the directory where the make was invoked to link the readout tasks.

6.7.1 Running a Single Processor System

Contents of the start procedure:

```
start task m_util
load setup setup.usf
clear daq counter
set trig_mod
start task m_read_meb "./m_read_meb"
start task m_collector
start task m_transport
```

This sequence should be kept since the commands rely on running tasks. The `START TASK` command starts tasks needed to run the system. `LOAD SETUP` parses the file `setup.usf` and loads it into memory. `CLEAR DAQ COUNTER` zeroes all run statistic numbers. `SET TRIG_MOD` initializes the trigger module. The readout task is taken from the local memory. No readout table is loaded, since the readout functions are already linked into the readout task.

6.7.2 Running a System with Slave Processors

In this example the startup of a system with an E7 as master event builder and two CVCs in two CAMAC crates as intelligent crate controller is described. The CVCs read their local crates and fill the subevent pipe residing in their local RAM. *NOTE* that the crate number is specified with the `load setup` command because CVCs do not know their own crate number. The E7 reads no

crate but collects the two subevents from the pipes via VSB.

To control the three processors from one terminal, one may use `prm` instead of `mbs`, see 4.7.1, page 25.

Contents of procedure to start environment on CVC in crate 1:

```
start task m_util
load setup setup.usf crate_nr=1
clear daq counter
disable cvc_cam_irq
set trig_mod
start task m_read_cam_slav "./m_read_cam_slav"
```

Contents of procedure to start environment on CVC in crate 2:

```
start task m_util
load setup setup.usf crate_nr=2
clear daq counter
disable cvc_cam_irq
set trig_mod -slave
start task m_read_cam_slav "./m_read_cam_slav"
```

Contents of procedure to start environment on E7 in VME crate:

```
start task m_util
load setup setup.usf
clear daq counter
start task m_collector
start task m_transport
```

Since there is no way for CVCs to read their crate number from the hardware it must be written into the setup segment by passing the crate number as parameter in the `load setup` command (`crate_nr=1,2`) on the slave controllers. One trigger module must be declared as master. The `SET TRIG_MOD` sets it per default as master, with the qualifier `-SLAVE` it is set as slave. The `START ACQUISITION` command must be executed on the controller which controls the master trigger module. The interrupt controller on the CVCs has to be disabled for CAMAC LAMs with `DISABLE CVC_CAM_IRQ` since the slave readout tasks work in the fast polling mode. Note that the same executables `m_read_cam_slave` are started on the CVCs and that the setup file loaded is the same for all 3 processors. On the E7 the master readout task is not started, because no crate has to be read by the branch master, but if needed this could also be configured easily.

6.7.3 Running a System with AEB Slave Processors

In this example again an E7 VME processor works as the master event builder. It has to collect subevents produced by one CVC and one AEB, thus it is mixture of all supported crate flavours.

The FASTBUS crate has the restriction that only slave trigger modules are supported, therefore the trigger module in the CAMAC crate must be master.

On the AEB only a restricted environment is available. In principle only one task needs to run (`m_read_aeb_slave`), which gets the setup quantities specified in a common setup file. Since the LynxOS and OS-9 NFS file systems cannot exchange data, a procedure is provided to load the setup file from the master event builder (which has to be a LynxOS host anyway), via VSB into the EBI memory of the AEB. On the AEB this memory section is read and all the setup quantities are moved into a save OS-9 memory module from where they can be accessed by the readout task. With this procedure it is possible to use only one copy of the `setup.usf` file for all controllers.

The commands to start up the slave readout task on the AEB are:

1. LynxOS: `dump_setup 2` (dumps the setup for AEB with crate number 2).
2. OS-9: `/mbs/prod/bin/m_read_setup_ebi` (reads setup file and writes it into memory module).
3. OS-9 `/mbs/prod/bin/m_read_aeb_slave` (starts slave readout task).

It is also possible to invoke 2. and 3. with the help of remote shell commands (`rsh`) from the LynxOS branch master, so no terminal access is needed for the AEB.

The startup procedures on the CVC and on the E7 are the same as described in the previous example.

Chapter 7

Multi-Layer Multi-Branch Systems

GMC_MBS_MBS

7.1 Introduction

Up to now the description of the MBS (**M**ulti-layer **m**ulti-**B**ranch **S**ystem) software has only covered single-branch systems including single-crate systems. This is, apart from improvements, just what was supported with the first version of this software package, which was named SBS (**S**ingle-**B**ranch **S**ystem).

With the MBS it is now possible to connect single-branch systems in an easy way together to form multi-branch or even a multi-layer systems. The method to combine single-branch systems is designed in such a way, that only one setup parameter (`COL_MODE`) inside a single-branch system has to be changed to switch it from a fully functional stand-alone single-branch system to a branch of a multi-branch system. This parameter specifies the output mode (output pipe) of a collector running on the branch master (see description of the setup parameters), thus allowing a versatile partitioning of a data acquisition system. For example it could be that subdetectors, which are read out by individual single-branch systems during a testing phase are combined to the complete data acquisition system in a production run, with virtually no change in the setup. It is also possible to go even a step further and combine two separately running multi-branch systems to one hierarchically structured multi-layer multi-branch system.

Generally it is possible to set up hierarchical structured (or multi-layered) data acquisition systems. On the lowest hierarchical level (layer 0) one has the branch masters controlling single branches. On the next hierarchical level (layer 1) some processors (multi-layer nodes) could collect the data provided by the branch masters. These nodes on layer 1 could itself write to output pipes which are read by a node of layer 2 and so on. This tree-like structure ends at the root with a single processor, the master event builder.

On all nodes above layer 0 a collector task must run to collect data from pipes in the layer just below. This collector can either format events into GSI buffers or write a single output pipe to be read by a collector of the layer just above, or do both. The pipes written by collectors are

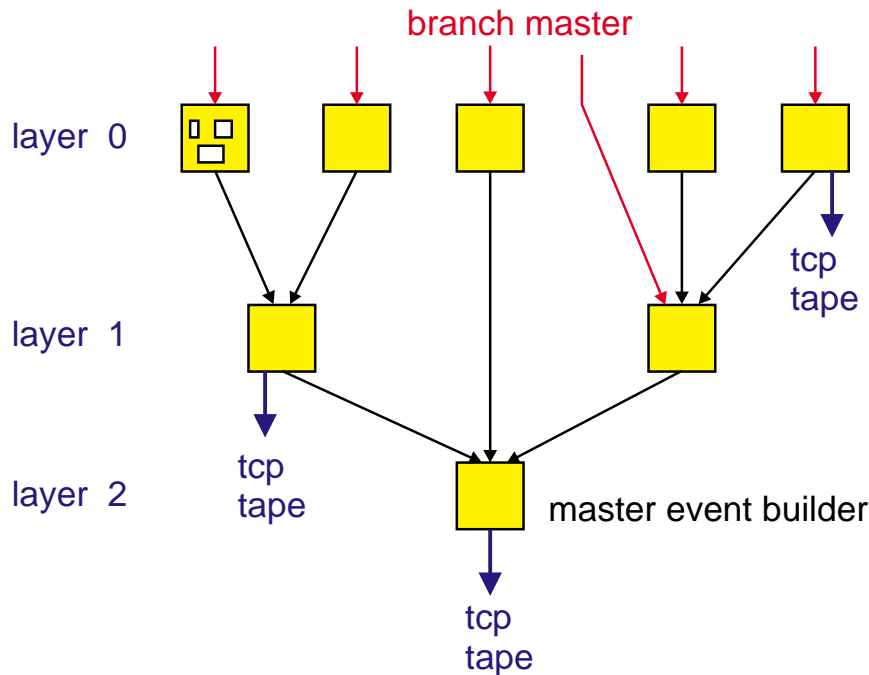

Figure 7.1: Logical View of a Multi-Layer Multi-Branch System (Top is low)

structured in the same way like the subevent pipes produced by the readout tasks. This means, that a collector doesn't care if the pipe it scans is filled by a readout task or by a collector in a lower layer. If the collector on a multi-layer node is used to format events, the `m_transport` task must run on this node. Optionally the event or stream server may also run on these nodes. This allows for writing data to TCP or tape on any multi-layer node and to do on-line monitoring of any subsystem data. It implies, however, that the complete system blocks if one output device connected to a transport task is not ready to take data.

If a single branch inside a multi-layer system is controlled by a single processor and no output to TCP or tape from this node is requested, no collector is allowed to run. Instead a collector on a higher layer must read the pipe filled by the `m_read_meb` task.

The collector task can write only one output pipe containing one or more subevents. These pipes are only allowed to be read by one collector in the next layer. Any node residing above layer 0 can run simultaneously as a branch master controlling a single branch and as a multi-layer node collecting data from nodes below its own layer. A collector may read from a node more than one layer below in hierarchy.

The pipe memories must (up to now) be address-mapped by both their producer and consumer. On each collector the consistency of the data merged together, like trigger type and the local event counter of the trigger modules, is checked.

Regardless of the structure of the data acquisition system, all trigger modules acting together with its readout tasks must be connected via their trigger bus. Only one trigger module must be

designated as the master trigger module. If an MBS system should be split into sub-systems for testing purposes the trigger bus must also be split. The new commands `ENABLE TRIG_MOD` and `DISABLE TRIG_MOD` allow for keeping or removing trigger modules logically from the trigger system even when the cabling remains unchanged. This doesn't help of course in the case mentioned above if systems are split or combined. In this cases the trigger bus cabling has to be appropriately adjusted.

To set up a multi-layer multi-branch system, the user has to provide the setups for all single branches in the standard way. Each node above layer 0 requires an additional setup facility. This is described in the next section.

7.2 Multi-Layer Multi-Branch Setup Specification

The parameters for a multi-layer multi-branch system are specified in one additional setup file (i.e. `ml_set.usf`). For each node in the system, this file must contain the setup facility `ML_SETUP`. It is loaded during an early phase in the startup of a system with the command `LOAD ML_SETUP`.

7.2.1 Setup File: Parameters

Now follows the description of the `ML_SETUP` parameters. The syntax is found in 8.1.2, page 76.

HOSTNAME : (string 15 useable chars) Simply the network node name of this processor.

RD_HOSTNAME_0 .. RD_HOSTNAME_15 : (array of strings, 15 useable chars each)
Network names of hosts where a pipe has to be collected from. This must be filled consecutively, always starting from `RD_HOSTNAME_0`.

RD_HOST_FLAG : (array) Flag corresponding to `RD_HOSTNAME_XY` to indicate the type of the node where to read from:

0 : nothing to read.

1 : pipe must be read, the node where to read from is a branch master.

2 : pipe must be read, the node where to read from is NOT a branch master but a node above layer 0.

Nodes where to read pipes from must also be indicated beginning with index 0 of the array and filling up consecutively.

SBS_SETUP_PATH_0 .. SBS_SETUP_PATH_15 : (array of strings, 127 useable chars each)
This parameter string is only required if `RD_HOST_FLAG` with the corresponding index indicates that a node where to read from is a branch master. The (full) pathname where the single-branch setup is found must be specified.

RD_PIPE_BASE_ADDR : (array) Specifies the base address of the pipes to read out, as seen from this host. The length and structure of the read pipe will be obtained by parsing either the single-branch setup file or the output pipe specification in the corresponding `ML_SETUP`

faciltiy in the `set_ml.usf` file. In this way the pipe specification is kept exclusively in one place.

OUT_MODE : Output mode of the collector running on this node:

- 1 : Write data from all read pipes into an output pipe.
- 2 : Format events into event buffer streams.
- 3 : Do 1 and 2.

The next three parameters are only required if `OUT_MODE = 1` or `3`.

WR_PIPE_BASE_ADDR : Base address of the collector output pipe.

WR_PIPE_LEN : Size of the collector output pipe (in bytes).

WR_PIPE_N_FRAG : Number of fragment slots which will be reserved in the collector output pipe. A fragment consists of either one or more subevents with its header.

The next three paramters are only required if `OUT_MODE = 2` or `3`. In the case where a processor acts as a branch master and as a multi-layer node and event formatting is required there is a clash where to specify the output buffer structure. In this case the appropriate values are taken from this `ML_SETUP` facility and NOT from the single-branch setup.

EV_BUF_LEN : Length in bytes of one buffer, multiples of 1024 up to 32768 are allowed.

N_EV_BUF : Number of buffers contained in one stream.

N_STREAM : Number of streams.

7.3 Example: Multi-Branch Setup

In this section an example will be shown where 4 single branches are connected together through one processor (E7_12) on layer 1. This example is actually the running KAOS experiment setup. Event formatting and monitoring is done only on E7_12. The four branches are:

1. A **CAMAC crate** with a CVC27 writing its subevent pipe into local memory.
 2. A **transputer system in FASTBUS** read out by E7_16 writing its subevent pipe into local memory.
 3. A **FASTBUS SMI** sequencer read out by E7_15 writing its subevent pipe into local memory.
 4. A **VME crate** read out by E7_14 writing its subevent pipe into a remote VME/VSB memory.
- The master event builder E7_12 collects the pipes from branch 1 via VSB and from branches 2-4 via VME.

The multi-branch setup file needed for E7_12 follows:

```
# N. Kurz
#
# user setup file (usf) for setting up the multi-layer multi-branch daq system
# see also parser definition file (pdf)
#
#*****

ML_SETUP: -
    HOSTNAME          = "E7_12", -

    RD_HOSTNAME_0     = "CVC27", -
    RD_HOSTNAME_1     = "E7_16", -
    RD_HOSTNAME_2     = "E7_15", -
    RD_HOSTNAME_3     = "E7_14", -

    RD_HOST_FLG       = (1,1,1,1,0,0,0,0,0,0,0,0,0,0,0), -

    SBS_SETUP_PATH_0 = "/kaos/usr/kaos/mbsrun/cam/setup_mbs.usf", -
    SBS_SETUP_PATH_1 = "/kaos/usr/kaos/mbsrun/trp/setup_mbs.usf", -
    SBS_SETUP_PATH_2 = "/kaos/usr/kaos/mbsrun/smi/setup_mbs.usf", -
    SBS_SETUP_PATH_3 = "/kaos/usr/kaos/mbsrun/vme/setup_mbs.usf", -

    RD_PIPE_BASE_ADDR = (0xf0202000, 0x50f00000, 0x40f00000, 0x01000000, -
                        0x0,          0x0,          0x0,          0x0, -
                        0x0,          0x0,          0x0,          0x0, -
                        0x0,          0x0,          0x0,          0x0), -
```

```
OUT_MODE          = 2, -
EV_BUF_LEN        = 0x4000, -
N_EV_BUF          = 8, -
N_STREAM          = 8
```

```
*****
```

7.4 Example: Multi-Layer Multi-Branch Setup

In this example a running test setup of a multi-layer multi-branch system will be shown. It consists of 3 branches with CVC38, CVC97 and CVC99 as branch masters (layer 0). In the above layer 1, E6_4 collects the pipe from CVC38 and writes it into an output pipe. E7_1, also in layer 1, collects the pipes from CVC97 and CVC99 and writes an output pipe. It also formats events into GSI buffers for taping and on-line monitoring. E7_2 in the event builder layer 2 collects the pipes from E6_4 and E7_1 and formats events into GSI buffers for taping and on-line monitoring. For the three processors in layers 1 and 2 ML_SETUP parameters must be provided and are shown below:

```
# N. Kurz
#
# user setup file (usf) for setting up the multi-layer multi-branch daq system
# see also parser definition file (pdf)
#
*****
# layer 1
ML_SETUP: -
  HOSTNAME          = "E6_4", -
  RD_HOSTNAME_0     = "CVC38", -
  RD_HOST_FLG       = (1,0,0,0,0,0,0,0,0,0,0,0,0,0,0,0), -
  SBS_SETUP_PATH_0 = "/daq/usr/kurz/mbstest/ml9/cam1/setup.usf", -
  RD_PIPE_BASE_ADDR = (0xf0200000, 0x0,      0x0,      0x0, -
                      0x0,      0x0,      0x0,      0x0, -
                      0x0,      0x0,      0x0,      0x0, -
                      0x0,      0x0,      0x0,      0x0), -
  OUT_MODE          = 1, -
```

```
WR_PIPE_BASE_ADDR    = 0x700000, -
WR_PIPE_LEN          = 0x40000, -
WR_PIPE_N_FRAG       = 200, -

#####
# layer 1
ML_SETUP: -
  HOSTNAME            = "E7_1", -

  RD_HOSTNAME_0       = "CVC97", -
  RD_HOSTNAME_1       = "CVC99", -

  RD_HOST_FLG         = (1,1,0,0,0,0,0,0,0,0,0,0,0,0,0), -

  SBS_SETUP_PATH_0    = "/daq/usr/kurz/mbstest/ml9/cam2/setup.usf", -
  SBS_SETUP_PATH_1    = "/daq/usr/kurz/mbstest/ml9/cam3/setup.usf", -

  RD_PIPE_BASE_ADDR   = (0xf0400000, 0xf0600000, 0x0,      0x0, -
                        0x0,      0x0,      0x0,      0x0, -
                        0x0,      0x0,      0x0,      0x0, -
                        0x0,      0x0,      0x0,      0x0), -

  OUT_MODE            = 3, -

  WR_PIPE_BASE_ADDR   = 0xf00000, -
  WR_PIPE_LEN         = 0x40000, -
  WR_PIPE_N_FRAG      = 300, -

  EV_BUF_LEN          = 0x1000, -
  N_EV_BUF            = 5, -
  N_STREAM            = 5

#####
# layer 2 = event builder
ML_SETUP: -
  HOSTNAME            = "E7_2", -

  RD_HOSTNAME_0       = "E6_4", -
  RD_HOSTNAME_1       = "E7_1", -

  RD_HOST_FLG         = (2,2,0,0,0,0,0,0,0,0,0,0,0,0,0), -
```

```
RD_PIPE_BASE_ADDR    = (0x4700000, 0x10f00000, 0x0,      0x0, -
                        0x0,      0x0,      0x0,      0x0, -
                        0x0,      0x0,      0x0,      0x0, -
                        0x0,      0x0,      0x0,      0x0), -

OUT_MODE              = 2, -

EV_BUF_LEN            = 0x4000, -
N_EV_BUF              = 6, -
N_STREAM              = 6
```

Chapter 8

Data Structures

GMC_MBS_DATA

8.1 Profile Definitions

A profile consists of text lines qualified by a facility name. Lines can be continued by a hyphen at the end. Each line specifies parameters and their data types defined for the facility. A parameter is defined by a name and a data type. The facility is followed by a colon, parameter specifications are separated by commas. A parser definition file looks like this:

```
facility: parameter=type, parameter=type, ...
facility: parameter=type, parameter=type, -
        parameter=type, parameter=type, ...
```

The type specification allows for integer (l), unsigned integer (ul), float (f), character (c), arrays ([dim]). For integers a range may be specified by {low:high}. Parameters may be specified as optional by appending an o to the type, i.e.:

```
fac1: key1=l[5], -
      key2=f, -
      key3=l{6,10}, -
      key4=co[20]
```

A data file must follow the specifications of a parser definition file. It looks then very similar, the type specification replaced by values:

```
facility: parameter=value, parameter=value, ...
facility: parameter=value, parameter=value, -
        parameter=value, parameter=value, ...
```

Example:

```
fac1: key1=(1,2,3,4,5), -
      key2=3.14, -
      key3=8, -
      key4="Abc"
```

Currently there are three parser definition files: For single branch setup profiles, for multi-branch setup profiles, and for readout table profiles.

In both kind of files, definition files and profiles, the # sign at the beginning of lines marks comments. Spaces are ignored.

8.1.1 Single-Branch Setup File

The setup parser definition file is `$MBSROOT/set/setup.pdf`: A detailed description of the user setup (setup.usf) file will be found in 6.3, page 49. Template user setup files are in the directories in `/mbs/prod/extra`.

```
# N. Kurz
#
# parser definition file (pdf) for setup
#
SBS_SETUP_TABLE: -
#
#       MASTER           = ULo, -
#
#       REM_MEM_BASE     = ULo[16], -
#       REM_MEM_OFF      = ULo[16], -
#       REM_MEM_LEN      = ULo[16], -
#
#       REM_CAM_BASE     = ULo[16], -
#       REM_CAM_OFF      = ULo[16], -
#       REM_CAM_LEN      = ULo[16], -
#
#       LOC_ESONE_BASE   = ULo, -
#       REM_ESONE_BASE   = ULo, -
#       ESONE_OFF        = ULo, -
#
#       LOC_MEM_BASE     = ULo[16], -
#       LOC_MEM_LEN      = ULo[16], -
#       CVC_CRR_OFF      = ULo, -
#       CVC_CSR_OFF      = ULo, -
#       CVC_CLB_OFF      = ULo, -
#
#       SE_MEB_ASY_LEN   = ULo, -
```

```

#
LOC_PIPE_BASE      = UL0[16], -
PIPE_OFF           = UL0[16], -
PIPE_SEG_LEN       = UL0[16], -
PIPE_LEN           = UL0[16], -
MAX_SE_LEN_TRGTYP1 = UL0[16], -
MAX_SE_LEN_TRGTYP2 = UL0[16], -
MAX_SE_LEN_TRGTYP3 = UL0[16], -
MAX_SE_LEN_TRGTYP4 = UL0[16], -
MAX_SE_LEN_TRGTYP5 = UL0[16], -
MAX_SE_LEN_TRGTYP6 = UL0[16], -
MAX_SE_LEN_TRGTYP7 = UL0[16], -
MAX_SE_LEN_TRGTYP8 = UL0[16], -
MAX_SE_LEN_TRGTYP9 = UL0[16], -
MAX_SE_LEN_TRGTYP10 = UL0[16], -
MAX_SE_LEN_TRGTYP11 = UL0[16], -
MAX_SE_LEN_TRGTYP12 = UL0[16], -
MAX_SE_LEN_TRGTYP13 = UL0[16], -
MAX_SE_LEN_TRGTYP14 = UL0[16], -
MAX_SE_LEN_TRGTYP15 = UL0[16], -

#
RD_FLG             = UL0[16], -
RD_TYP             = UL0, -
CONTROLLER_ID      = UL0[16], -
SY_ASY_FLG         = UL0[16], -
MEB_ASY_FLG        = UL0, -
COL_MODE           = UL0, -
ML_PIPE_BASE_ADDR  = UL0, -
ML_PIPE_SEG_LEN    = UL0, -
ML_PIPE_LEN        = UL0, -
N_COL_RETRY        = UL0, -

#
MEB_TRIG_MODE      = UL0, -
SPECIAL_MEB_TRIG_TYPE = UL0, -
SPECIAL_MEB_TRIG_BASE = UL0, -
TRIG_STAT_NR       = UL0[16], -
TRIG_FCT           = UL0[16], -
TRIG_CVT           = UL0[16], -

#
CVC_IRQ            = UL0, -
CVC_IRQ_LEN        = UL0, -
CVC_IRQ_SOURCE_OFF = UL0, -

```

```
    CVC_IRQ_MASK_OFF    = ULo, -
#
    EV_BUF_LEN          = ULo, -
    N_EV_BUF            = ULo, -
    N_STREAM            = ULo, -
#
    EVT_TYP_SY          = ULo, -
    EVT_TYP_ASY         = ULo, -
    EVt_SUBTYP_SY       = ULo, -
    EVT_SUBTYP_ASY      = ULo, -
    SE_TYP              = ULo[16], -
    SE_SUBTYP           = ULo[16], -
    SE_CONTROL          = ULo, -
    SE_PROCID           = ULo[16]-
#
```

8.1.2 Multi-Branch Setup File

The multi-branch setup parser definition file is `$MBSROOT/set/set.ml.pdf`: A detailed description will be found in 7.2, page 67. Template setup files are in the directories in `/mbs/prod/exa`.

```
# N. Kurz 10-Jan-1996
#
# parser definition file (pdf) for multi-layer multi-branch daq system
#
ML_SETUP: -
#
    HOSTNAME            = Co[16], -
#
    RD_HOSTNAME_0       = Co[16], -
    RD_HOSTNAME_1       = Co[16], -
    RD_HOSTNAME_2       = Co[16], -
    RD_HOSTNAME_3       = Co[16], -
    RD_HOSTNAME_4       = Co[16], -
    RD_HOSTNAME_5       = Co[16], -
    RD_HOSTNAME_6       = Co[16], -
    RD_HOSTNAME_7       = Co[16], -
    RD_HOSTNAME_8       = Co[16], -
    RD_HOSTNAME_9       = Co[16], -
    RD_HOSTNAME_10      = Co[16], -
    RD_HOSTNAME_11      = Co[16], -
    RD_HOSTNAME_12      = Co[16], -
```

```

RD_HOSTNAME_13      = Co[16], -
RD_HOSTNAME_14      = Co[16], -
RD_HOSTNAME_15      = Co[16], -
#
RD_HOST_FLG         = UL0[16], -
#
SBS_SETUP_PATH_0    = CO[128], -
SBS_SETUP_PATH_1    = CO[128], -
SBS_SETUP_PATH_2    = CO[128], -
SBS_SETUP_PATH_3    = CO[128], -
SBS_SETUP_PATH_4    = CO[128], -
SBS_SETUP_PATH_5    = CO[128], -
SBS_SETUP_PATH_6    = CO[128], -
SBS_SETUP_PATH_7    = CO[128], -
SBS_SETUP_PATH_8    = CO[128], -
SBS_SETUP_PATH_9    = CO[128], -
SBS_SETUP_PATH_10   = CO[128], -
SBS_SETUP_PATH_11   = CO[128], -
SBS_SETUP_PATH_12   = CO[128], -
SBS_SETUP_PATH_13   = CO[128], -
SBS_SETUP_PATH_14   = CO[128], -
SBS_SETUP_PATH_15   = CO[128], -
#
RD_PIPE_BASE_ADDR   = UL0[16], -
#
OUT_MODE            = UL0, -
#
WR_PIPE_BASE_ADDR   = UL0[16], -
WR_PIPE_LEN         = UL0[16], -
WR_PIPE_N_FRAG     = UL0[16], -
#
EV_BUF_LEN          = UL0, -
N_EV_BUF            = UL0, -
N_STREAM            = UL0 -

```

8.1.3 Readout Tables

See also 6.5, page 56. The readout table parser definition file is `$MBSROOT/set/readout.pdf`:

```

# Parser Definition File
# -----
# Author : N.K, RSM

```

```
# Date   : 02-Dec-1993
# Vers   : 1.00
# Purpose: Prototype for MBS - CAMAC - Initialize and Readout
# =====
```

```
INITFILE: -
           file=c[64]
```

```
READFILE: -
           file=c[128], -
           trigger=l{0:15}
```

```
CAMREAD:  -
           crate      =l{0:15}, -
           nstation   =l{1:24}, -
           address     =l{0:15}, -
           function    =l{0:32}, -
           repetition  =ulo
```

```
CAMINIT:  -
           crate      =l{0:15}, -
           nstation   =l{1:32}, -
           address     =l{0:15}, -
           function    =l{0:32}, -
           data        =lo, -
           repetition  =ulo
```

Note that the CNAFs for initialization and readout corresponding to each trigger must be contained in separate files.

8.2 List Mode Data Structures

8.2.1 Glossary

byte : 8-bit-sequence

word : 2 bytes

longword : 4 bytes.

buffer element : Whole buffer or part of a buffer.

buffer element header : Unified structure keeping information about the trailing buffer element data.

buffer element data : Data of any structure including other buffer elements. Always preceded by a buffer element header.

event : Data describing one physical event. Events are buffer elements in standard buffers. Events may be composed of subevents.

If not otherwise stated:

All length fields are given in 16-bit word units excluding two longwords of header.
All character string fields are written with 7-bit ASCII coding.

8.2.2 Byte Order

Between machines with different byte ordering, a longword swap must be performed. All structures in this manual refer to the 68000 byte ordering (**Big Endian**: least significant bit is in byte with highest address). When using these structures on Little Endian architectures such as OpenVMS, the bytes in a longword must be swapped and all word or byte declarations must be declared in reversed order, i.e.:

```
short i_subtype;  
short i_type;  
char h_begin;  
char h_end;  
short i_used;
```

must be declared on a Little Endian machine (like OpenVMS) as:

```
short i_type;  
short i_subtype;  
short i_used;  
char h_end;  
char h_begin;
```

8.2.3 Buffers

The MBS dump file format defines the structure of dumps of data produced by MBS for later analysis or exchange of data between MBS and other systems. It is identical with the GSI (GOOSY) structures. The smallest entities of data, which are transported by MBS in the sense mentioned above, are called *buffers*. Presently these buffers have a fixed-length of multiples of 1024 up to 32768. On disk, the buffers are stored in one RMS record, while on tape several buffers can be stored into one tape record.

- **Buffer Element**

An MBS buffer contains an arbitrary number of buffer elements. Any buffer element is composed of two parts:

- **Buffer Element Header**

Headers work like envelopes for data. Examples for headers are the buffer header (see below) and the event header (see below). The header specifies the type and size of the following data. Size is in words excluding two longwords of header.

- **Buffer Element Data**

Arbitrary structured data. The structure may contain other buffer elements. The type specified in the buffer element header must always uniquely define the kind of data following.

Examples of buffer elements are the buffer itself, MBS events and MBS subevents. The event headers always contain a type/subtype number combination which is unique for a certain data structure. All modules processing buffers can check if a buffer element has the correct type. If not, it may just skip the element, output messages or skip the buffer.

8.2.4 Buffer Files

If MBS buffers are dumped to files, the first buffer may be a GSI file header buffer (see below)! If the file is written to a tape, the tape is labeled by **ANSI tape labels** as described in the ANSI standard (American National Standard X3.27-1978). In general, MBS uses DEC's standard RMS file formats. The MBS files contain fixed-length records.

8.2.5 GSI File Header Buffer

The include files for all structures described in the following are on Lynx directory `/mbs/prod/inc`. The file names are the same as the structure names. On OpenVMS machines the corresponding PL/1 declarations are in library `GOOINC`. **Big Endian representation:**

```
struct cv_string
{
    short string_1;
    char string[78];
}
```

```
};
struct s_filhe
{
short filhe_tlen;
short filhe_dlen;      /* length of data in words      */
short filhe_subtype;  /* = 1                               */
short filhe_type;     /* = 2000                            */
short filhe_frag;
short filhe_used;
long  filhe_buf;
long  filhe_evt;
long  filhe_current_i;
long  filhe_stime[2];
long  filhe_free[4];  /* free[0] = 1 -> swap              */
short filhe_label_l; /* length of tape label string      */
char  filhe_label[30]; /* tape label                        */
short filhe_file_l;  /* length of file name              */
char  filhe_file[86]; /* file name                         */
short filhe_user_l;  /* length of user name              */
char  filhe_user[30]; /* user name                        */
char  filhe_time[24]; /* date and time string             */
short filhe_run_l;  /* length of run id                 */
char  filhe_run[66]; /* run id                           */
short filhe_exp_l;  /* length of explanation            */
char  filhe_exp[66]; /* explanation                      */
long  filhe_lines;  /* # of comment lines              */
struct cv_string s_strings[30]; /* max 30 comment lines            */
};
```

8.2.6 GSI Buffer Element Header

Each header, i.e. of events or subevents, has at least one standard header which looks like (**Big Endian representation**):

```
typedef struct
{
long  l_dlen;      /* Length of following data in words */
short i_subtype;  /* Number specifying element structure */
short i_type;     /* Number specifying element structure */
} s_evhe;
```

NOTE: The length field always counts the 16-bit words following this header, even if specific headers are longer! The only exception is the buffer header itself. The structure of a specific

header should be known from the `type/subtype` numbers. However, each data element can be skipped without knowing the header structure following this standard header.

8.2.7 GSI Buffer

Big Endian representation:

```
/* Generated from SA$BUFHE.TXT */
typedef struct
{
long l_dlen; /* Length of data field in words */
short i_subtype;
short i_type;
char h_begin; /* Fragment begin at end of buffer */
char h_end; /* Fragment end at begin of buffer */
short i_used; /* Used length of data field in words */
long l_buf; /* Current buffer number */
long l_evt; /* Number of fragments */
long l_current_i; /* Index, temporarily used */
long l_time[2]; /* Time stamp */
long l_free_0; /* Byte order longword = 1 */
long l_free_1; /* Length of last event in buffer */
long l_free_2; /* = 0 */
long l_free_3; /* = 0 */
/* data field */
} s_bufhe;
```

Event Spanning

When an event does not fit into a buffer, the total length of the event is copied into `l_free_1` of the buffer header. The length field in the event header is then changed to the actual number of words of the event fitting into the buffer. Then the byte `h_begin` is set in the buffer header. Then the next buffer is used. Byte `h_end` is set in the buffer header. A standard element header (2 longwords: length, type, subtype) is written and then the remaining event data. The length field of the element header is the number of words following.

8.2.8 Streams and Buffers

A *stream* is a set of contiguous GSI buffers. Events may span over buffers but not over streams. A stream is always locked by one task, i.e. the collector to fill it, or the transport to empty it. When a stream is not filled completely it may be that there are empty buffers in it. These have `l_dlen = 0`.

8.2.9 Event Structures

Event

Big Endian representation:

```
/* Generated from EE$ROOT:[GOOFY.VME]SA$VEHE.VMETEMP; */
typedef struct
{
  long l_dlen;      /* Data length + 4 in words      */
  short i_subtype; /* Subtype                       */
  short i_type;    /* Type number                   */
  short i_trigger; /* Trigger number                */
  short i_dummy;  /* Not used yet                  */
  long l_count;   /* Current event number          */
} s_vehe;
```

Subevent

Big Endian representation:

```
/* Generated from EE$ROOT:[GOOFY.VME]SA$VESHE.VMETEMP; */
typedef struct
{
  long l_dlen;      /* Data length +2 in words      */
  short i_subtype; /* Subtype                       */
  short i_type;    /* Type number                   */
  char h_control;  /* Processor type code           */
  char h_subcrate; /* Subcrate number              */
  short i_procid;  /* Processor ID [from setup]    */
} s_veshe;
```

For table readout the data per CAMAC channel is

```
typedef struct
{
  short i_data;    /* CAMAC data value             */
  short i_index;   /* CAMAC parameter table index  */
} s_data;
```

When using the standard readout mechanism (readout tables), the CAMAC data follows as 1 word (16bit) channel data and 1 word channel number. Channels with a data value of zero are suppressed.

8.2.10 Types and Subtypes

Type Numbers

Type numbers in general should specify data structures. A GSI file header buffer has a different structure than a GSI data buffer. Therefore the type of the header buffer is 2000 and shall not be used for other buffers. Within events, the type number specifies which data structure follows, i.e. straight values, or subevents.

Subtype Numbers

The subtype numbers may be chosen by experiments to store specific information.

Buffer

Currently there are some type numbers already in use:

- 2000,1**: GSI file header buffer
- 4,1**: GSI data buffer with events of type 4.
- 10,1**: GSI data buffer with events of type 10.

Event

Currently there are some type numbers already in use:

- 3**: Events with a standard header followed by compressed data.
- 4**: Events with a standard header followed by the data. The subtype specifies if zeros are suppressed.
- 10**: Events with structure `s_vehe` followed by subevents with structure `s_veshe`.

Subevent

- 10**: Subvents with structure `s_veshe`.

8.3 Command Definition File

A typical entry in the command definition file looks like this:

```
# 1+ Command *****
# + Module      : SBSCOM.CDF
# 2+Command*****
# + Command keys: SHOW COMMANDS
# + Command     : SHOW COMMANDS [task] /FULL /ALL
#
# + PURPOSE     : Show known commands.
# + PARAMETERS  :
```

```
# + task      : Optional task name to show commands
# + /FULL     : Commands with arguments.
# + /ALL      : All commands with arguments
# 2+Description*****
# + Function  : Show all known commands (including the commands of
#              inactive tasks by /ALL).
# + Routine   : f_disp_sho_cmd
# + Task      : m_dispatch
# 1- *****
m_dispatch
    SHOW COMMANDS
    task=co[16],/FULL,/ALL
```

Chapter 9

Event Serving and Filtering

GMC_MBS_EVSERV

9.1 Stream Server

There is a new version of the MBS stream server. It provides several operation modes for best performance in different setups. In all modes the scale factor controls the DAQ performance.

The default mode after startup is same as by following command:

```
mbs> set stream_server scale=2 -NOSYNC -NOKEEP
```

This means, for every 2nd stream the server checks if a client requested a stream.

9.1.1 Synchronous Mode

The new synchronized mode is enabled by switch `-SYNC`:

```
mbs> set stream_server scale=<n> -SYNC
```

This means, for every nth stream the server waits for the client's request, of cause only if a client is connected. With $n=1$, the client gets all streams and defines the acquisition speed.

9.1.2 Asynchronous Modes

In `-NOSYNC` mode there are two variants of `-KEEP` modes:

Conditional Keep

```
mbs> set stream_server scale=<n> -KEEP
```

With $n=1$, the server keeps each stream as long as there are more than 3 free streams available. The effect is that during spill pauses the client will get as many streams as it requests (if there are any), but the acquisition speed may slow down especially at high event rates but low data rates. With $n>1$, keeping is switched off and the mode is like `-NOKEEP`.

Scaled Keep

```
mbs> set stream_server scale=<n> -SCALE
```

The server keeps every n th stream as long as there are more than 3 free streams available. The effect is that during spill pauses the client will get streams on request, but maybe not as many as in `-KEEP` mode. At the other hand in `-SCALE` mode the impact on the acquisition speed can be controlled. With $n=1$, this mode is the same as `-KEEP`.

The `SHOW STREAM_SERV` command has been enhanced and displays the mode and counters. The counters are only incremented if a client is connected.

One should play with the modes to get the best compromise of DAQ performance and data transfer rate for monitoring.

When a client, i.e. a GOOSY Transport Manager, connects to the stream server, the server sends first four longwords with information about buffer sizes and streams:

1. Endian longword, must be 1
2. Buffer size [bytes]
3. Buffers per stream
4. Number of streams

After this the client must request a stream by sending three longwords (all zero) and then read one complete stream. The GOOSY Transport Manager checks if the buffer parameters are conform to its own ones and disconnects, if not.

9.2 Transport Server

When a client, i.e. a GOOSY Transport Manager, connects to the MBS Transport the server sends first four longwords with information about buffer sizes and streams:

1. Endian longword, must be 1
2. Buffer size [bytes]
3. Buffers per stream
4. Number of streams

This is the same information as the stream server sends after accepting a client. After this the client must read buffer by buffer. The GOOSY Transport Manager checks if the buffer parameters are conform to its own ones and disconnects, if not.

Note: The buffer size can be specified in GOOSY TMR by command

```
INIT ACQ /TCP size=<bytes>
```

But this command can only be executed once! Therefore the TMR must be restarted to change the buffer sizes.

9.3 Event Server

This server runs on Lynx as a component of MBS. The client handling is the same as in the GOOSY PAW server. Clients may use both servers without change. The difference is that the event server is written entirely in C and that it gets its data from MBS buffer streams.

9.4 Remote Event Server

The remote event server connects as client to a Stream Server running on the front-end and receives on request complete buffer streams from there. A buffer stream consists of a number of buffers with events acquired with the MBS system. Depending on the parameters specified for the remote event server and on the filter conditions valid for the clients, some or all events received from the stream server are passed over the network to connected Event Clients.

On Alpha VMS workstation, after execution of the command `TOOLLOGIN`, two symbols concerning the Remote Event Server are set:

1. `REVSERVER`, the command for invocation, and
2. `REVSERVNEW`, the command to switch to the new version.

Default is the production version.

On AIX workstations, the executables are available in

1. `/usr/local/bin/revserver` (production version) and
2. `/usr/local/bin/revservnew` (new version).

9.4.1 Parameters

Starting the remote event server there are ten parameters available. The first two are required and specify node name and port number of the stream server, whereas the other parameters are optional. All parameters in detail:

1. `node`: the node name of the front-end running the data acquisition.
2. `port_no.:` the port number of the stream server on the front-end (6002 normally).
3. `clients.:` the maximum number of event clients connected at a time (default = 3).
4. should be zero (default).

5. **server_mode:**
 - 0: quiet (default)
 - 1: verbose
 - 2: measure the event rate processed by the remote event server
 - 3: measure the maximum event rate delivered by the stream server (without event clients).
6. **streams:** scaledown of buffer streams to be processed for the clients (default = 1 : take all incoming streams).
7. **events:** the maximum number of events to be processed per buffer stream (default: -1 : all events).
8. **max_look:** if not all clients are ready to receive the next event: the maximum number of calls looking for further clients becoming ready (default = 1000).
9. **add_look:** the maximum number of additional calls looking for further clients becoming ready. Used for synchronization purposes in case of nearly identical clients (in % of the calls needed for the first client, client_mode 0 only) (default = 100 %)
10. **client_mode:**
 - 1: the remote event server processes the next event, if at least one client is ready (thus ignoring all not ready clients for this event)
 - 2: before processing the next event, the remote event server waits until all clients are ready, or for at least max_look calls
 - 0: if not all clients are ready: wait some additional calls (add_look); this is recommended for nearly identical clients (default: 0).

The last three parameters specify the treatment of the connected clients and strongly influence the event throughput.

9.4.2 Tuning

When invoking the remote event server the throughput to the Event Clients must be optimized according to your specific requirements. Appropriate tools are available to handle several conflicting scenarios:

1. All clients are nearly identical. This means that the hardware platforms and network connections are equivalent, and for all clients nearly the same amount of event filtering and analysis is performed. This scenario is valid in most cases and requires normally maximum throughput in the sum of all clients.
2. Some clients are different, and the fastest client(s) shall receive an event rate as high as possible.

3. Some clients are different, and the slowest client(s) shall receive as many events as possible.

There are three parameters available to specify your environment and to optimize the event throughput according to your needs (`max_look`, `add_look`, and `client_mode`, see Remote Event Server, parameters 8-10). The underlying principle to increase the overall event throughput is: wait a very short time in the right place to get more clients ready for the next event.

Reasonable values for the three scenarios above are:

1. `client_mode = 0`, `max_look = 1000`, `add_look = 100` (default)
2. `client_mode = 1`, `max_look = 0`, `add_look = 0`
3. `client_mode = 2`, `max_look = 5000`, `add_look = 0`

Fine tuning can be done by the user with the option `server_mode` set to 2 (see Remote Event Server, parameter 5). Then the time needed to process each 100 buffer streams is measured and the resulting processed event rate in [kbyte/sec] is presented.

In parallel the event clients should be started with `climode = t`. Then also the corresponding clients present the processed event rate in [kbyte/sec] (for each 1000 events received, new client version V13 only). Varying `max_look` and `add_look` with `server_mode = 2` you should be able to find the optimal values according to your requirements.

9.5 GOOSY On-line Analysis

9.5.1 GOOSY Transport Manager

There are several ways to connect GOOSY to an MBS and get data from it. The transport manager must be initialized by command

```
GOOSY> INITIALIZE ACQUISITION/TCP SIZE=buffersize COUNT=buffers.
```

The buffersize must match the MBS buffersize (default is 16K).

Connection to MBS Transport

With GOOSY command `CONNECT TRANSPORT` one connects to the transport server and starts the GOOSY acquisition. All data are transferred to the GOOSY transport manager. Analysis programs may get data from there in a standard way. **Caution!** Depending on the MBS transport setting, writing to tape may be suspended.

Connection to MBS Stream Server

With command `CONNECT STREAM` one connects to the stream server and starts the GOOSY acquisition. This opens an asynchronous channel. Samples of data are transferred to the GOOSY transport manager. Analysis programs may get data from there in a standard way. The buffersize must match the MBS buffersize (default is 16K). The number of buffers in the TMR must be greater/equal then the number of buffers in one stream.

Disconnect

Disconnect from stream server or transport by `DISCONNECT STREAM/TRANS`. The GOOSY acquisition is stopped automatically.

9.5.2 GOOSY Analysis

Standard GOOSY analysis programs can get event buffers from an MBS event server by GOOSY command `START INPUT EVENT`. The analysis then gets data via TCP.

```
START INPUT EVENT <node> PORT=<port>
STOP INPUT EVENT
```

where 'node' and 'port' are specific. The event server port is 6003. A more detailed description of the event filtering can be found in chapter 9, page 87. It is the same as for the GOOSY PAW server. The event server must run and be enabled by MBS command `START EVENT_SERV`.

GMC_MBS_PAW

9.6 PAW On-line Analysis

The following informations can also be obtained in the WWW at (<http://www.gsi.de/computing/expdv/event.html>).

To solve the conflict between the needs for a stable version and the permanent requirements for new functions, there are two versions available for the remote event servers and the clients:

1. a new version, which may be subject of changes due to functional enhancements, and
2. a production version, which is frozen, but may be replaced a (very) few times per year by the current new version.

There are three different clients available providing the HBOOK data structures in shared memory (in VMS: permanent global sections) or conventionally in the user's address space:

1. A stand-alone (non-PAW) program providing the data in shared memory,
2. A PAW module providing the data in shared memory (AIX only), and
3. A PAW module providing the data in the user's address space.

The clients have a Fortran user interface to create and fill HBOOK data structures (histograms and Ntuples) for further analysis and visualization with PAW. In the last two cases the client is integrated into PAW. In case 3, for visualization and further analysis the HBOOK histograms and Ntuples are accessible only in the current PAW session. In case of shared memory usage, however, the data can be accessed in parallel by any number of additional PAW sessions running on the same node as the client. Note, that case no. 2 is not supported on OpenVMS!

All clients work with the CERN software versions 94a and later. Event analysis on the client side is controlled by user written interface programs (in Fortran) defined similarly to those of the APE package:

- uastart:** create HBOOK histograms and Ntuples
- uanal4:** fill HBOOK histograms and Ntuples
- uastop:** user actions before end of analysis
- uclinfo:** user statistics routine (new version only)

The following sections describe the clients on OpenVMS and AIX.

9.7 PAW Clients on VMS

The first command should be `cernlogin` to setup all definitions needed to use PAW, and to specify the version of the CERN software to be used. If you like to use the new version of the client software, invoke the command `goopawnew`. All modules you need to create your event clients are then available on directory `goopaw`.

For a non-PAW client using shared memory (case 1 above) you need:

- `make_gooshrcli.com` : command file to create your client
- `link_gooshrcli.com` : link script called in `make_gooshrcli.com`

```
uastarts.for      : called at the begin of input
uanal4.for        : template program for the analysis of events
uastop.for        : called at the end of input
uclinfo.for       : returns current statistics
```

For a PAW client collecting the data in the PAW common data block PAWC in the user's address space (number 3 above) the relevant modules are:

```
make_goopawcli.com : command file to create your PAW client
link_goopawcli.com : link script called in make_goopawcli.com
uastartc.for       : called at the begin of input
uanal4.for        : template program for the analysis of events
uastop.for        : called at the end of input
uclinfo.for       : returns current statistics
```

Copy the templates to your own file system and fill them with your analysis code. See also the extensive in-line documentation in the template files. If further user modules or libraries are needed, copy also the required command files `make...` and `link...` and modify them correspondingly.

Note that there are two different template files containing the initialization subroutine, namely `uastarts.for` for data collection in shared memory, and `uastartc.for` for data collection in the PAW common data block PAWC in the user's address space. These file names are also used in the corresponding command files creating the executables. However, the name of the Fortran subroutine must be `uastart` in both cases.

In the shared memory version, the client is a standalone program without PAW environment. For visualization and further analysis the HBOOK histograms and Ntuples filled in the global section can be accessed in parallel by any number of PAW sessions running on the same node. If the client is invoked repeatedly, the HBOOK data structures are initialized each time in the template procedure `uastart` thus losing the previous contents.

In the version with the client integrated into PAW, the HBOOK histograms and Ntuples are accessible only within the current PAW session. Here the HBOOK data structures are initialized by default only once, so that all events received from all client invocations may be accumulated. However, optionally the data structures may be initialized for each call of the client (see 9.9, page 99).

Warning: The current VMS releases of the Cern software do not support writing to global sections within PAW. Therefore don't use the shared memory initialization in PAW, else your PAW session will be corrupted after the first invocation of the client!

9.7.1 PAW as Client for the Event Server in VMS

Having prepared the four Fortran user interfaces `uastartc.for`, `uanal4.for`, `uastop.for`, and `ucinfo.for` (optionally, in new version only) in your local directory, your PAW executable containing the client for the Event Server will be created and invoked by the commands

```
@goopaw:make_goopawcli
goopawcli
```

Within PAW, the client will be invoked with the command

```
PAW > /gsi/goocli/input <argument-list>
```

For the argument list see 9.9, page 99, the AIX man page `goocli`, or the on-line help information available in your session PAW with

```
PAW > help /gsi/goocli
```

Here several help menus are offered providing information on

- o the command interface of the client,
- o the event-filter (including extensive examples),
- o the user interfaces for event analysis control,
- o and some general informations, including some hints on the client version writing to shared memory.

The HBOOK histograms and Ntuples, as booked in `uastart` and filled in `uana14`, are available only in the common data block PAWC in the current PAW session. If the client is running, pressing CTRL-g invokes the call of a user modifiable (FORTRAN) subroutine `uclinfo` that may display statistical information. The client can be terminated with CTRL-a.

9.7.2 Using VMS Global Sections with PAW

Having prepared the four Fortran user interfaces in your local directory, the non-PAW client program will be created and invoked by the commands

```
@goopaw:make_gooshrcli
gooshrcli <argument-list>
```

For the argument list see 9.9, page 99, or the AIX man page `gooshr`. The client allocates a global section (if not already existing) containing the HBOOK histograms and Ntuples as booked in `uastart` and filled in `uana14`. You may access these data from any number of (standard) PAW sessions running on the same host. A sample PAW session accessing these data might look as follows:

```
PAW > global <section>
```

The global section named `<section>` is mapped. This name must be identical with that used in `uastart`!

Caution: PAW requires **capital letters** for the name of the global section!

The following PAW command sequence executes without change on AIX and VMS.

```
PAW > zone 1 3
PAW > idle 1 'h/pl 1 ; h/pl 2 ; h/pl 3'
```

In this example the display window is prepared for three displays. The last PAW command (`idle`) means that if nothing is typed at the keyboard for 1 second, you will see plots of IDs=1,2,3. You can type at any time at the keyboard to interrupt this sequence. To stop this sequence, type

```
PAW > idle 0
```

If a big number of events is provided, you can see your histograms growing in time. You can do this also with overlays, i.e.:

```
PAW > h/pl 1 k ; h/pl 2 k ; h/pl 3 k
PAW > idle 1 'h/pl 1 u ; h/pl 2 u ; h/pl 3 u'
```

The global section on VMS is permanent! If it is no longer needed, remove it with the DCL command

```
delgs <section>
```

You can get a list of your global sections with DCL command

```
ssec
```

To change the size of your global section, it **must** be deleted first, and then created again!

9.8 PAW Clients on AIX

The first command should be `cernlogin` to setup all definitions needed to use PAW, and to specify the version of the CERN software to be used. As mentioned above, on AIX three clients are available: A non-PAW client using shared memory, a PAW client using shared memory, and a PAW client using private memory. All modules you need to create an AIX client are available in the directories `/cern/goopaw`, or - for the new client software version - `/cern/goopawnew`. The following templates and make files are needed for the three types of clients:

Non-PAW client collecting data in shared memory:

```
gooshr.make      : make file
uastarts.f       : called at the begin of input
uanal4.f         : template program for the analysis of events
uastop.f         : called at the end of input
uclinfo.f        : returns current statistics
```

PAW client collecting data in shared memory:

```
goopawshr.make   : make file
uastartc.f       : called at the begin of input
uanal4.f         : template program for the analysis of events
uastop.f         : called at the end of input
uclinfo.f        : returns current statistics
```

PAW client collecting data in private address space:

```
goopaw.make      : make file
uastartc.f       : called at the begin of input
uanal4.f         : template program for the analysis of events
uastop.f         : called at the end of input
uclinfo.f        : returns current statistics
```

The Fortran template files should be copied from there to a private directory and filled with your analysis code. If you do not need further program modules, you can execute the make files directly to create the new version of the stand-alone shared memory client, e.g.:

```
cd <mydir>
make -f /cern/goopawnew/gooshr.make
```

Only the new version of the make files (in /cern/goopawnew) supports `uclinfo` as user interface. Note that there are two different template files containing the initialization subroutine, namely `uastarts.f` for the non-PAW client, and `uastartc.f` for the two PAW clients. These file names are also required in the corresponding make files. However, the name of the Fortran subroutine must be `uastart` in all cases.

The make files check and handle the version of the CERN software as specified with the `cernlogin` command. All three AIX clients work with the versions 94a and later of the CERN software. Without shared memory, the HBOOK histograms and Ntuples are accessible only within the current PAW session. The data structures created and filled in shared memory, however, can be accessed for visualization and further analysis in parallel by any additional number of PAW sessions running on the same node.

A PAW executable can be created with only one of the two clients integrated. For more information see the extensive in-line documentation in the template Fortran files in /cern/goopaw[new].

If the non-PAW client is invoked repeatedly, the HBOOK data structures are initialized each time thus losing their previous contents. In case of the PAW clients, by default the HBOOK data structures are initialized only once, so that all events received from all client invocations are accumulated. However, optionally the data structures may be initialized also for each call of the client (see 9.9, page 99).

9.8.1 PAW as Client for the Event Server in AIX

Having prepared the four Fortran user interfaces `uastartc.f`, `uanal4.f`, `uastop.f`, and `ucinfo.f` (optionally, in new version only) in your local directory, PAW clients using shared memory will be created and invoked with

```
make -f /cern/goopaw/goopawshr.make
goopawshr
```

whereas PAW clients using private memory are built and invoked by

```
make -f /cern/goopaw/goopaw.make
goopaw
```

The client will be invoked in both cases with the PAW command

```
PAW > /gsi/goocli/input <argument-list>
```

For the argument list see 9.9, page 99, the AIX man page `goocli`, or the on-line help information available with

```
PAW > help /gsi/goocli
```

in the same way as on VMS.

9.8.2 Writing to Shared Memory outside PAW

Having prepared the Fortran user interfaces in your local directory, the non-PAW client will be created and invoked with

```
make -f /cern/goopaw[new]/gooshr.make
gooshr <argument-list>
```

For the argument list see 9.9, page 99, or the AIX man page `gooshr`. As PAW clients using shared memory, the non-PAW client allocates shared memory segments (if not already existing) containing the HBOOK histograms and Ntuples as booked in `uastart` and filled in `uana14`. You may access these data from any number of (standard) PAW sessions running on the same host.

9.8.3 Accessing Shared Memory with PAW

A sample PAW session reading from shared memory might look as follows:

```
PAW > global <segment>
```

The specified shared memory segment `<segment>` is mapped. This name must be identical with that used in `uastart`!

Then the same sequence as shown above (chapter 9.7.2, page 95) may be executed.

Caution: You should replace the name of the shared memory segment in the templates by your own individual name, because any user on the same node can read from this area, if he knows the name and maps it!

The shared memory segment is permanent! If it is no longer needed, remove it with the AIX command

```
ipcrm -m <segment-id>
```

The number <segment-id> of the shared memory segment can be obtained with the AIX command

```
ipcs -mbc
```

To change the size of your shared memory segment, it **must** be deleted first and then created again!

9.9 Argument Description for Event Clients

See also man pages `goocli` or `gooshr` on AIX. The arguments are the same on VMS and AIX.

9.9.1 Function

Connect to a (Remote) Event Server and request a number of events. Under control of user written interface programs, HBOOK spectra and Ntuples are created and filled, either in shared memory or in the user's address space (private memory).

All arguments except `imode` are the same for the non-PAW client (see man `gooshr`).

9.9.2 Arguments

host-name : The name of the host running the (Remote) Event Server.

port-no : The port number of the (Remote) Event Server (6003).

event-no : optional

> 0 : the number of events requested from the server.

0 : test mode, e.g. for the filter conditions. The client will be started with the given arguments but the connection to the server will NOT be established.

-1 : Request an unlimited number of events from the server.

Default: 500

filter : optional

Specify filter conditions on events or subevents to be applied by the server:

A : Select all events/subevents.

F : Filter conditions will be prompted.

filename: Name of a file containing the filter conditions.

Default: A

sample-rate : optional

0 : The server tries to send every event that matches the filter.

> 0 : The server tries to send every n'th event that matches the filter.

Default: 0

echo-rate : optional

> 0 : Get notification after every n'th event.

< 0 : Get notification after every n percent of the requested number of events (if event-no > 0 only).

0 : Disable echo.

Default: -10

list-flag : optional

This flag has two functions:

1. Select extent of event/subevent data display:

N : No display

H : Display only event/subevent headers

D : Display event/subevent headers and data

(decimal for subevents of subtypes 1,2; hex for others)

2. Switch on/off user analysis routine UANAL4:

X : Switch off user analysis routine UANAL4

Combinations of both types of flags are allowed.

Defaults: N, UANAL4 invoked

flush : optional

Buffer flushing interval. The server sends a buffer every **flush** seconds. If the buffer contains no event data, the client notifies with a message on standardout.

Default: 2

imode : optional

Control invocation of initialisation routine UASTART.

0 : call UASTART only the first time

> 0 : call UASTART at each invocation of the client

Default: 0

climode : optional

Define client mode.

Q : quiet, (nearly no) output to standardout

V : verbose mode

T : benchmark mode. After each 1000 events received, the transfer rate (kbyte/sec) is shown.

Default: Q

9.9.3 Example

```
PAW > /gsi/goocli/input clri6f 6003 -1 a 1 500
```

Connect to a Remote Event Server running with port number 6003 on the AIX node 'clri6f', and request a continuous stream of events. All events sent from the stream server on the front end to the Remote Event Server are passed to the client if ready. After each 500 received events a notification appears on standardout. The server sends a buffer each two seconds.

```
PAW > /gsi/goocli/input axp605 6003 10000
```

Connect to a Remote Event Server running on the Alpha VMS node 'axp605', and request all of the next 10,000 events. After each 1,000 events (10%) a notification appears on standardout.

9.10 Filters

The clients can specify *event-filters* to get only events with certain characteristics and/or *copy-filters* to get only parts of these events. A complete *filter set* is made out of one *copy-filter subset* and several *event-filters subsets*. Each subset is made of several specification lines with nine values each. Due to the potential complexity of filters it is recommended to write one filter set specification in one text file. In these files there are lines according to the following syntax:

```
! <comment>
! subset 1 -----
<number of specification lines n>
<line 1> ! Nine values for each line
...
<line n>
! subset 2 -----
<number of specification lines m>
<line 1> ! Nine values for each line
...
<line m>
...
! subset i -----
...
```

9.10.1 Copy-Filter

The client may get the whole event that matched the event-filter, or only parts of such an event as specified by a copy-filter. This selection is independent of the event-filter, e.g. the event-filter may check the trigger number and a pattern in one subevent, but the copy-filter may specify two other subevents to be received by the client.

9.10.2 Event-Filter

Event-filters may be applied on events of type `s_vehe` and/or on subevents of type `s_veshe` (see 8.2.9, page 83). A complete filter set consists of a subset with the copy-filter specifications and one or more subsets with event-filter specifications. In simple cases, you need only one subset for both, copy- **and** event-filter (see examples).

Description

The lines of one event-filter subset may be combined with logical operators. Event-filter subsets also can be combined with logical operators. Each subset applies on a different region of the event (e.g. 1st subset on event header, trigger number etc., 2nd subset on a certain subevent etc. ...). In case of a subevent, one must unambiguously specify in the first entry of the filter subset on which subevent the subset shall be applied (by giving e.g. the processor id).

In order to maintain performance, all filter specifications are internally translated into bit masks and offsets. The masks and offsets must be word or longword aligned in the event. The event specific filter subsets must come first, followed by optional subevent specific filter subsets.

Filter Subset Specification

The specification lines for event-filter and copy-filter have the same nine fields, separated by spaces:

1. Target : Specify target for event- or copy-filter

1 event
0 subevent

2. Event : Line is in event-filter subset

0 no
1 yes

3. Copy : Line is in copy-filter subset

0 no
1 yes

4. Operator : The specified mask and object (see below) are connected by the following operators. The result is TRUE or FALSE:

0 !! (ALL)
1 == (IDENT) : object == mask
2 && (ANY) : object & mask
3 &= (INCL) : (object & mask) == object
4 ^= (EXCL) : (object & mask) == mask

```

5 < (LT)      : object < mask
6 >= (GE)     : object >= mask

```

5. Operator : The lines in a filter subset are connected by

```

0 OR
1 AND

```

6. Operator : The filter subsets are connected by

```

0 OR
1 AND

```

7. Object : Object specification. The referenced names are from structures `s_vehe` and `s_veshe`, see 8.2.9, page 83.

```

0 Take all
1 Object is trigger longword (event header)
2 Object is pattern and offset ([sub]event header)
4 Object is type word ([sub]event header)
8 Object is subtype word ([sub]event header)
12 Object is subtype & type longword ([sub]event header)
16 Object is procid word (subevent header)
32 Object is control & subcrate word (subevent header)
48 Object is control & subcrate & procid longword (subevent header)

```

8. Mask : Mask (=bit pattern) to compare with object specified as decimal or hex (0x.....).

9. Offset : Offset for object type 2 specified as decimal or hex (0x.....).

```

>= 0 Longword offset in event or subevent (0 = 1st LW, ..., etc.)
< 0 Word offset in event or subevent (0 = 1st W, -1: 2nd W, ..., etc.)

```

9.10.3 Filter Examples

The following are filter file examples. Text behind an ! is comment! The lines with the argument numbers are for better reading and refer to the description above.

Simple Event-Filter

Event-filter: Take all events with trigger `>= 3`

```

! copy-filter subset
1                      ! 1 line follows
! 1 2 3 4 5 6 7 8 9 ! argument numbers
  1 0 1 0 0 0 0 0 0 ! copy-filter
! event-filter subset

```

```
1                ! 1 line follows
! 1 2 3 4 5 6 7 8 9 ! argument numbers
  1 1 0 6 0 0 1 3 0 ! event-filter
```

This simple example can be also written as

```
1                ! subset with 1 line
! 1 2 3 4 5 6 7 8 9 ! argument numbers
  1 1 1 6 0 0 1 3 0 ! copy and event-filter line
```

Complex Event-Filter

Event-filter: Take all events with
(trigger = 3) **OR** (trigger = 7)

AND

the first three bits set in the 16th LongWord of the subevent with procid=20.

```
! copy-filter subset
1                ! subset with 1 line
! 1 2 3 4 5 6 7 8 9 ! argument numbers
  1 0 1 0 0 0 0 0 0 ! copy-filter = all
! event-filter subset 1
2                ! subset with 2 lines
! 1 2 3 4 5 6 7 8 9 ! argument numbers
  1 1 0 1 0 1 1 3 0 ! Trigger = 3
  1 1 0 1 0 1 1 7 0 ! Trigger = 7
! event-filter subset 2
2                ! subset with 2 lines
! 1 2 3 4 5 6 7 8 9 ! argument numbers
  0 1 0 1 1 1 16 20 0 ! procid = 20
  0 1 0 4 1 1 2 7 15 ! mask 7, offset 15 LW.
```

Copy- and Event-Filter

Event-filter is like before, but copy-filter selects only subevents with procid=10 or 20.

```
! copy-filter subset
2                ! subset with 2 lines
! 1 2 3 4 5 6 7 8 9 ! argument numbers
  0 0 1 1 0 0 16 10 0 ! procid = 10
  0 0 1 1 0 0 16 20 0 ! procid = 20
! event-filter subset 1
2                ! subset with 2 lines
! 1 2 3 4 5 6 7 8 9 ! argument numbers
```

```
1 1 0 1 0 1 1 3 0      ! Trigger = 3
1 1 0 1 0 1 1 7 0      ! Trigger = 7
! event-filter subset 2
2                          ! subset with 2 lines
! 1 2 3 4 5 6 7 8 9      ! argument numbers
0 1 0 1 1 1 16 20 0      ! procid = 20
0 1 0 4 1 1 2 0x7 0xF    ! mask 7, offset 15 LW.
```

9.11 General Purpose Event I/O Library

GMC_MBS_EVT

To extract data from the acquisition system and write GSI standard buffers there is a set of routines available on all GSI platforms (VMS, AIX, DECunix, Lynx). The routines are for open/close event input/output streams. Input could be an MBS transport, MBS stream server or a file. Output can be a file. Several input and output channels may be open at the same time.

Then each call of `f_getevt_get` gets an event whereas `f_putevt_put` writes an event. The event interpretation/formatting is up to the caller. Events for output must, however, have at least the two longwords standard GSI header (see 8.2.6, page 81). The formatting of the buffer is done by the routines.

The sources are on AIX and DECunix in directory `/usr/local/GSI/getevt`, the objects are in `/usr/local/GSI/AIX/lib/libgsi.a` and `/usr/local/GSI/AXP/lib/libgsi.a`, respectively. On OpenVMS the sources are in directory `TOOL$SOURCE`, the objects in library `TOOL$LIB:TOOLIB.OLB`.

The routines are described in the MBS reference manual. A brief description follows here:

f_getevt_open	(long Lmode, char &c_server[], s_channel &s_chan, char **ppc_server_info) f_getevt_open opens an event stream from specified channel.
f_getevt_get	(s_channel &s_chan, long **ppl_buffer, long **ppl_goobuf) f_getevt_get returns address of event
f_getevt_close	(s_channel &s_chan) f_getevt_close closes event stream of specified channel.
f_getevt_error	(long Lerror , char &c_string[], long Lout) f_getevt_error displays error messages.
f_putevt_open	(char *c_file[], long Lsize, long Lstream, long Ltype, long Lsubtype, s_channel *ps_chan, char *ps_filhe) f_putevt_open opens an event output stream.
f_putevt_put	(s_channel *ps_chan, long &la_evt_buf[]) f_putevt_put outputs event
f_putevt_close	(s_channel *ps_chan) f_putevt_close closes specified channel.
f_putevt_error	(long Lerror , char &c_string[], long Lout) f_putevt_error displays error messages.

Chapter 10

Histogramming

GMC_MBS_HISTO

10.1 Introduction

In order to allow on-line data analysis and histogramming, the MBS histogramming tool has been developed. It consists of:

- Histogram Manager program: `m_histogram`
- Analysis routine: `f_his_anal`
- Histogram Server thread
- Histogram client library

10.1.1 Histogram Manager

The MBS Histogram Manager can be started from the shell by command `histogram` or in an MBS environment by the MBS command `START TASK m_histogram`. The histogram manager allows data bases for histograms with the dimensions of 1 and 2 to be created. All operations on histograms may be done within this program package. Histogram contents may be written in files with an exchangeable format. Thus histograms can be imported or exported from GOOSY, PAW and SATAN. Whole bases can be dumped and restored into files.

10.1.2 Analysis Template

There is a user-modifiable C-code template that allows histogramming during on-line data acquisition on the Multi-Branch System. This analysis routine `f_his_anal` is called in the MBS collector task before the subevents are copied into the event buffers. A make file is provided for linking the `m_collector` with the modified module `f_his_anal`.

10.1.3 Histogram Server

The histogram manager provides a server functionality to send histograms to clients. Clients on any GSI supported platform have to be written by users. A library provides routines to copy histograms out of an MBS system into any program for further processing.

10.2 Histogram Manager

10.2.1 General Description

The histogram manager runs in an MBS environment. The software package is designed to create data bases and histograms within them. The package also provides all commands for manipulating these bases and histograms including saving histograms and base contents into files.

For the time being, the MBS system is being implemented on Lynx/OS. On this POSIX operation system, the histogram data bases are organized as shared segments in order to allow reading/writing access from different tasks. So histograms may be accessed by routine `f_his_anal` called in program `m_collector` and controlled by commands executed by program `m_histogram` at the same time. Figure 10.1 shows the access. API is the set of routines used to access the histograms within `f_his_anal`. In routine `f_his_anal` a decision can be made, if the current

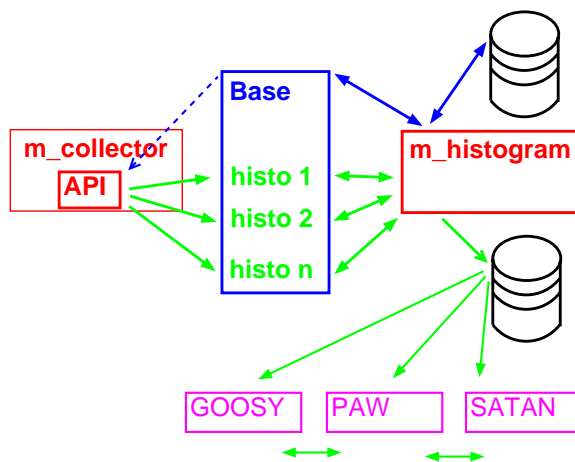

Figure 10.1: Histogram Access.

event should be skipped or copied into the output buffers. The program `m_histogram`, and routine `f_his_anal` may refer to the same base, or to two different data bases. In the case of one base at the same time, a lock mechanism always ensures the integrity of the data (see figure 10.2, page 109). The histogram base internally consists of a directory for the histogram entries and a pool for the data itself, as can be seen in figure 10.3, page 110. The length of the directory table, i.e. the maximum number of histograms in the base, must be specified. The approximate length

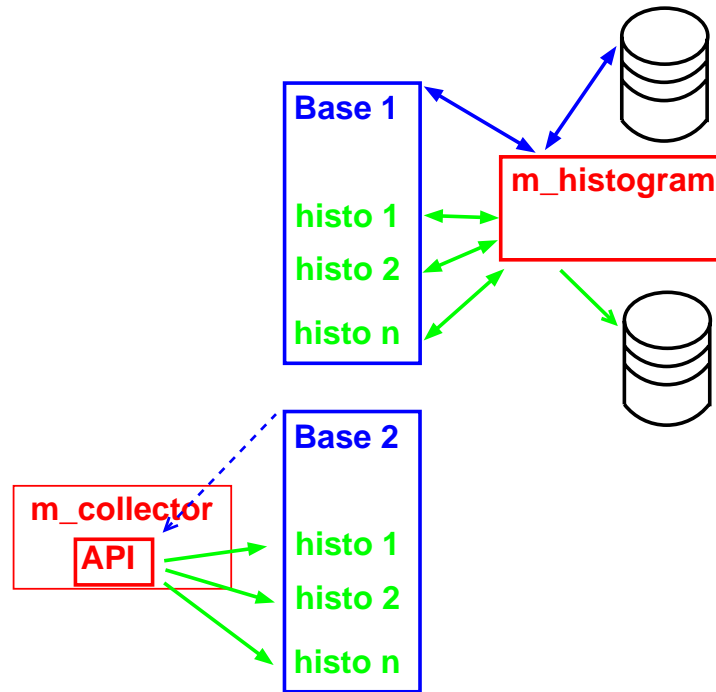

Figure 10.2: Histogram Access with Two Bases.

for one entry is 352 bytes. The size of the data pool has to be specified. Each histogram is described by a header with the following structure:

```

struct s_spe
{
    unsigned long ul_attr;           /* flag                               */
    short         i_slotlef;        /* next slot left (sort)             */
    short         i_slotrig;       /* next slot right (sort)            */
    long          l_bins_1;        /* number of bins in dim=1           */
    long          l_bins_2;        /* number of bins in dim=2           */
    long          l_dim;           /* dimension size                     */
    long          l_data;          /* relative pointer to data,
                                   * Offset LW                          */
    unsigned long l_counts;        /* total sum of counts                */
    double        d_contents;
    /* + + + dim = 1 + + + */
    long          l_outlim_up_counts; /* no of counts that are             */
}

```

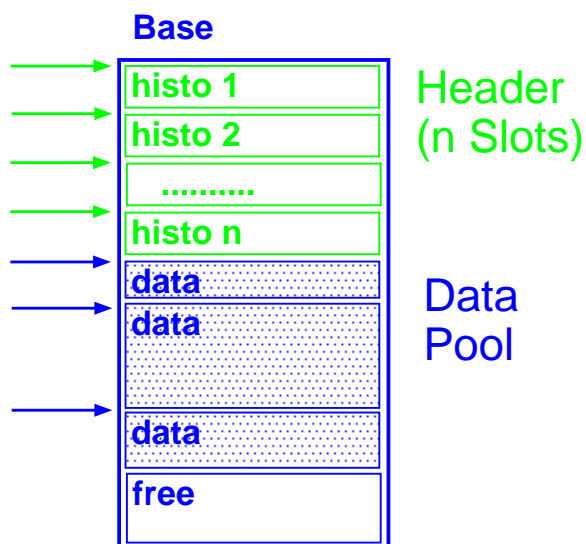

Figure 10.3: Histogram Data Base Structure.

```

long      l_outlim_low_counts; /* out of range          */
float     r_limits_low;       /* energy limits    */
float     r_limits_up;
float     r_factor;           /* linear trans.    */
float     r_offset;
/* + + + dim = 2 + + + */
long      l_outlim_up_counts_2; /* no of counts that are */
long      l_outlim_low_counts_2; /* out of range          */
float     r_limits_low_2;       /* energy limits dim = 2 */
float     r_limits_up_2;        /* energy limits dim = 2 */
float     r_factor_2;           /* linear trans.        */
float     r_offset_2;
/* +++ character strings +++ */
char      c_name[16];           /* spect's name        */
char      c_dtype[4];          /* data flag           */
char      c_data_time_cre[28]; /* creation time       */
char      c_clear_date[28];
char      c_lettering_res[64]; /* lettering data content */
char      c_lettering_1[64];   /* lettering 1st axis  */
char      c_lettering_2[64];   /* lettering 2nd axis  */
};

```

10.2.2 Histogram Command Overview

A detailed description of the commands can be found in the MBS command description manual. All commands except `ENABLE/DISABLE` are executed in the histogram manager program `m_histogram`. Commands for histogram bases:

```
CREATE BASE
DELETE BASE
ATTACH BASE
DETACH BASE
DUMP BASE
RESTORE BASE
SHOW BASE
```

Commands for histograms:

```
CREATE HISTOGRAM
CLEAR HISTOGRAM
DELETE HISTOGRAM
DUMP HISTOGRAM
SHOW HISTOGRAM
SET HISTOGRAM CHANNEL
SET HISTOGRAM TEXT
ENABLE HISTOGRAM
DISABLE HISTOGRAM
SET VERBOSE HISTOGRAM
```

10.3 Histogramming

10.3.1 General Description

The histogram manager package allows to manage histograms. These may be filled with on-line data by the routine `f_his_anal` written by the user. In order to do that, histogramming must be enabled for the base to be used (see below). The return status of `f_his_anal` allows individual events to be selected or suppressed in the output buffer, i.e. on-line data reduction.

While histogramming is enabled, histograms may not be deleted. A template for `f_his_anal.c` is available on `/mbs/prod/eva`. The user has to modify it. First each referenced histogram has to be located: In the initialization part of `f_his_anal.c`, the user refers to the histogram by its name in the locate function `f_his_anal_ini(...)` that returns two pointers for accessing the histogram.

Histograms are accumulated by two functions (`f_his_accu1` and `f_his_accu2`) for one and two dimensions, respectively. Two pointers refer the histogram, one to the table entry, the other to the data field. Coordinates and increment value have to be specified as floating point variables. The bin(s) will be automatically calculated from the limit(s) and number(s) of channels (see 10.4, page 115).

The flowchart of the subevent processing is shown in figure 10.4.

10.3.2 Enabling and Disabling Histogramming

Histogramming can be enabled and disabled by two commands executed in the collector task:

- **ENABLE HISTOGRAM** <base> Enable histogramming. The specified histogram data base must exist as a shared segment. Otherwise it must be created or restored first. If the subevents are not available on the local memory but must be accessed via VSB, the **ENABLE/DISABLE EVENTCOPY** command may increase the performance. When this flag is set, the subevents are copied once into a local event buffer where they can be accessed faster by subsequent processing, i.e. analysis and event formatting.
- **DISABLE HISTOGRAM** Disable histogramming, detach collector task from the histogram base.

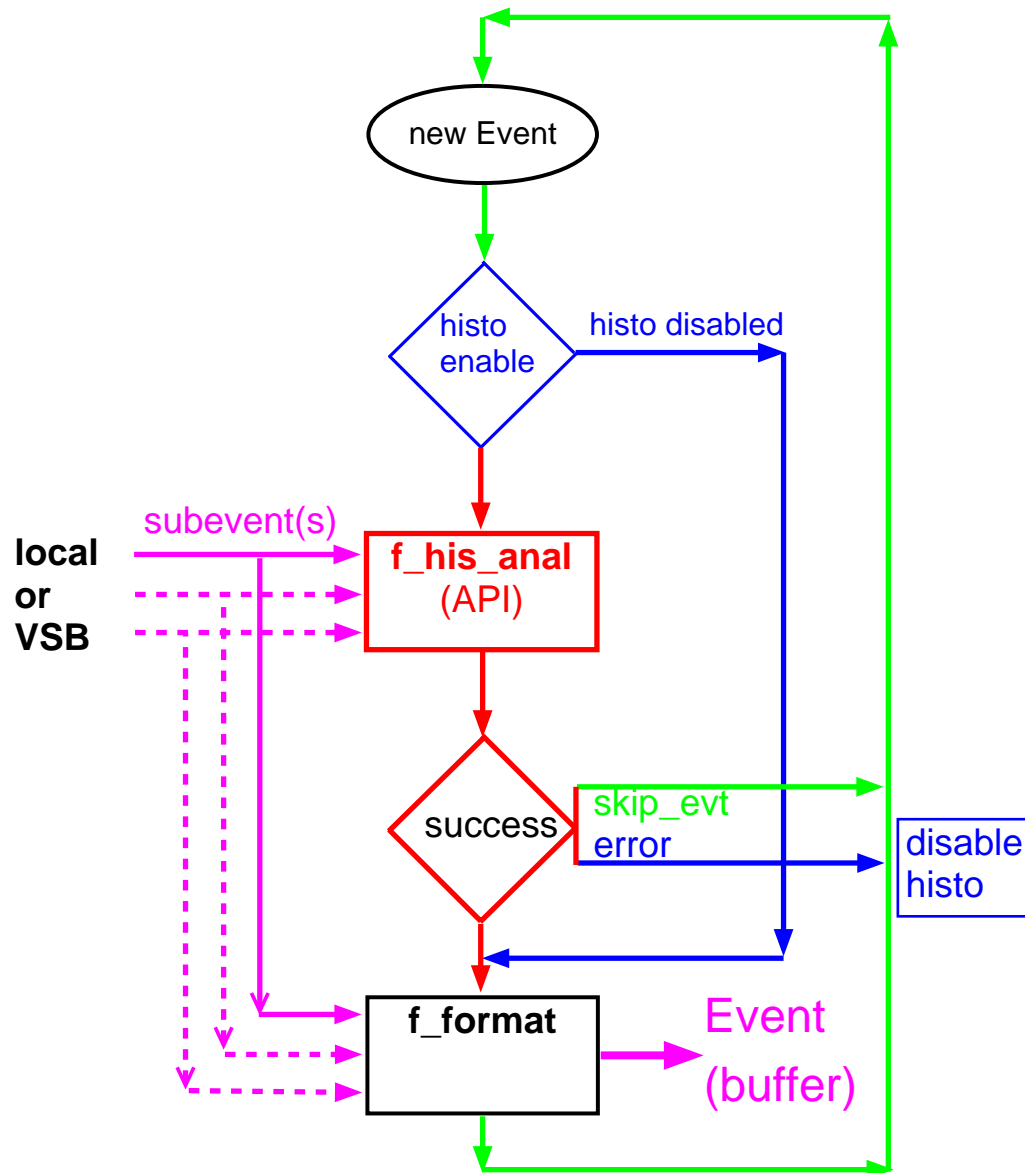

Figure 10.4: On-line Analysis Flow Chart.

10.3.3 `f_his_anal`: Event Access and Return Status

The analysis routine has access to the event data before the event is formatted into the usual standard event structure or a user defined one. Therefore the event access is conducted with the help of the structure `s_form` in which the addresses of the subevents are given:

```
struct s_form
{
    unsigned char    bh_ev_begin_flg;
    unsigned char    bh_trig_typ;
    long             lp_stream_seg;
    long             lp_stream_ctr;
    unsigned char    bh_n_frag;
    long             *pl_dat_start[MBS__N_CR+1];
    unsigned long    bl_dat_len[MBS__N_CR+1];
    unsigned long    lp_daq_status;
};
```

The important parts of the structure for this purpose are:

`bh_trig_typ`: Trigger type

`bh_n_frag`: Number of subevents (so called event fragments)

`*pl_dat_start[i]`: virtual pointer to data fragment, i.e. subevent.

`bl_dat_len[i]`: length of data fragment in bytes.

with $0 \leq i < \text{bh_n_frag}$.

The details of the subevent (fragment) data structure depend on the readout (see 5.2.3, page 30).

The following return status values of `f_his_anal` are interpreted by the collector:

`ERR__SUCCESS`: Successful completion.

`ERR__ERROR`: Fatal error. Disabling histogramming will be done.

`ERR__HIS_EANAL`: Error in `f_his_anal`, but no disabling will be done.

`ERR__HIS_SKIPEVT`: Skip event.

`ERR__HIS_SKIPSEV`: Not yet implemented.

10.4 Histogramming Functions

The routines are described in the MBS reference manual. A brief description follows here:

f_his_anal	<code>lstatus = f_his_anal(ps_form)</code> Template for analysis program.
f_his_anal_ini	<code>lstatus = f_his_anal_ini(ps_head, pps_spe, ppl_data, c_hisname)</code> Initialize histogram for analysis routine.
f_his_accu1	<code>lstatus = f_his_accu1(ps_spe, pl_data, r_energy, r_incr)</code> Accumulate histogram dim=1 in analysis routine.
f_his_accu2	<code>lstatus = f_his_accu2(ps_spe, pl_data, r_energy1, r_energy2, r_incr)</code> Accumulate histogram dim=2 in analysis routine.

10.5 Histogram Server

To process histograms generated inside MBS in other program systems, one method is to dump the histograms to ASCII files, transfer these via TCP to the desired computers and read them into these programs. For GOOSY and PAW this method is provided, but yet somewhat inconvenient. Therefore one can use a histogram server inside MBS and a client library elsewhere on any GSI supported platform which provides routines to copy histograms out of an MBS system. The server is started as thread by histogram manager command

```
start histogram server
```

The routines are described in the MBS reference manual. A brief description follows here:

10.6 Histogram Client Library

- | | |
|----------------------|---|
| f_his_gethist | (CHARS *pc_node, CHARS *pc_basename, CHARS *pc_hisname, CHARS **ppc_buf, INTS4 *pl_buflen)
Get histogram data from histogram server. |
| f_his_getdir | (CHARS *pc_node, CHARS *pc_basename, CHARS **ppc_buf, INTS4 *pl_buflen)
Get histogram list in a base from histogram server. |

Chapter 11

ESONE Library

GMC_MBS_ESONE

11.1 Esone Clients

The libraries to build ESONE clients are:

VMS: `TOOL$LIB:ESONECLI.OLB`

AIX: `/usr/local/GSI/AIX/lib/libesonecli.a`

DECunix: `/usr/local/GSI/AXP/lib/libesonecli.a`

Lynx: `/mbs/prod/esone/lib/libesonecli.a`

On all UNIX platforms descriptions are available via `help`. On VMS a help library is on `TOOL$LIB:ESONE.HLB`. The routines are described in the MBS reference manual. A brief description follows here:

cccc	<code>int cccc(long EXT)</code> generate dataway clear
cccd	<code>int cccd(long EXT, int L)</code> Enable or Disable Crate Demand
ccci	<code>int ccci(long EXT, int L)</code> Set or clear Dataway inhibit.
cccz	<code>int cccz(long EXT)</code> generate dataway initialize
ccopen	<code>int ccopen(char *HOSTNAME, long *HOSTADD)</code> Enable or Disable Crate Demand
cdreg	<code>int cdreg(long *EXT, long B, int C, int N, int A)</code> Declare CAMAC register

cerror	char *cerror(int ERROR, int FLAG) Simple error handling routine
cfga	int cfga(int *FUNC, long EXT, int *DATA, int *Q, int *CB) General multiple CAMAC action
cfmad	int cfmad(int FUNC, long EXT, int *DATA, int *CB) Address scan mode
cfsa	int cfsa(int FUNC, long EXT, int *DATA, int *Q) Perform single CAMAC action
cfubc	int cfubc(int FUNC, long EXT, int *DATA, int *CB) Controller synchronized block transfer
cfubr	int cfubr(int FUNC, long EXT, int *DATA, int *CB) Controller synchronized block transfer
cgreg	int cgreg(long EXT, long *B, int *C, int *N, int *A) Analyse register identifier
csga	int csga(int *FUNC, long EXT, int *DATA, int *Q, int *CB) General multiple CAMAC action (16-bit words)
csmad	int csmad(int FUNC, long EXT, int *DATA, int *CB) Address scan mode 16-bit
cssa	int cssa(int FUNC, long EXT, int *DATA, int *Q) Perform single CAMAC action with 16 bit data words
csubc	int csubc(int FUNC, long EXT, int *DATA, int *CB) Controller synchronized block transfer (16-bit)
csubr	int csubr(int FUNC, long EXT, int *DATA, int *CB) Controller synchronized block transfer (16-bit)
ctcd	int ctcd(long EXT, int *L) Test crate demand enabled

ctci int ctci(long EXT, int *L)
 Test Dataway inhibit

ctgl int ctgl(long EXT, int *L)
 Test Crate Demand present

ctstat int ctstat(int *L)
 test status of preceding camac action

Chapter 12

Keyword Summary

MBS_keywords

Keywords In the following, the MBS command keywords are listed with their occurrence in the commands.

ACCESS

REMOTE ACCESS

ACQUISITION

SHOW ACQUISITION
START ACQUISITION
STOP ACQUISITION

ATTACH

ATTACH BASE

BASE

ATTACH BASE
CREATE BASE
DELETE BASE
DETACH BASE
DUMP BASE
RESTORE BASE
SHOW BASE

CAMAC

CAMAC CNAF
CAMAC FILE

CHANNEL

SET HISTOGRAM CHANNEL

CLEAR

CLEAR DAQ_STATUS COUNTER
CLEAR DAQ_STATUS PROCTAB
CLEAR DAQ_STATUS STATUS
CLEAR HISTOGRAM
CLEAR PIPES
CLEAR TRIG_MOD

CLOSE

CLOSE FILE

CNAF

CAMAC CNAF
CNAF

COMMANDS

DEFINE COMMANDS
SHOW COMMANDS

COMMENT

COMMENT

CONNECT

CONNECT DISPATCHER

COUNTER

CLEAR DAQ_STATUS COUNTER

CREATE

CREATE BASE
CREATE HISTOGRAM

CVC_CAM_IRQ

DISABLE CVC_CAM_IRQ
ENABLE CVC_CAM_IRQ

CVC_IRQ_MASK

SHOW CVC_IRQ_MASK

DAQ_STATUS

CLEAR DAQ_STATUS COUNTER
CLEAR DAQ_STATUS PROCTAB
CLEAR DAQ_STATUS STATUS

DEFINE

DEFINE COMMANDS

DELETE

DELETE BASE
DELETE HISTOGRAM

DETACH

DETACH BASE

DISABLE

DISABLE CVC_CAM_IRQ
DISABLE EVENT_COPY
DISABLE HISTOGRAM
DISABLE TCP
DISABLE TRIG_MOD

DISCONNECT

DISCONNECT DISPATCHER

DISMOUNT

DISMOUNT TAPE

DISPATCHER

CONNECT DISPATCHER
DISCONNECT DISPATCHER
SET DISPATCHER
SET VERBOSE DISPATCHER
SHOW DISPATCHER

DUMP

DUMP BASE
DUMP HISTOGRAM

ENABLE

ENABLE CVC_CAM_IRQ
ENABLE EVENT_COPY
ENABLE HISTOGRAM
ENABLE IRQ
ENABLE TCP
ENABLE TRIG_MOD

ENVIRONMENT

SHOW ENVIRONMENT

ESONE_SERV

SET MAXCLIENTS ESONE_SERV
SET PRINT ESONE_SERV
SET VERBOSE ESONE_SERV
SHOW ESONE_SERV

EVENT

TYPE EVENT

EVENT_COPY

DISABLE EVENT_COPY
ENABLE EVENT_COPY

EVENT_SERV

SET EVENT_SERV
SET MAXCLIENTS EVENT_SERV
SET VERBOSE EVENT_SERV
SHOW EVENT_SERV
START EVENT_SERV

FILE

CAMAC FILE
CLOSE FILE
OPEN FILE

FILEHEADER

SET FILEHEADER

FLUSHTIME

SET FLUSHTIME

GLOBAL

SET VERBOSE GLOBAL

HELP

HELP

HISTOGRAM

CLEAR HISTOGRAM
CREATE HISTOGRAM
DELETE HISTOGRAM
DISABLE HISTOGRAM
DUMP HISTOGRAM
ENABLE HISTOGRAM
SET HISTOGRAM CHANNEL
SET HISTOGRAM TEXT
SET VERBOSE HISTOGRAM
SHOW HISTOGRAM

INITIALIZE

INITIALIZE TAPE

IRQ

ENABLE IRQ

LOAD

LOAD ML_SETUP
LOAD READOUT
LOAD SETUP
LOAD SLAVE_READOUT

MAXCLIENTS

SET MAXCLIENTS ESONE_SERV
SET MAXCLIENTS EVENT_SERV

MESSAGE

SHOW MESSAGE
START MESSAGE

ML_SETUP

LOAD ML_SETUP
SHOW ML_SETUP

MOUNT

MOUNT TAPE

NEWS

NEWS

OPEN

OPEN FILE

PIPES

CLEAR PIPES

PRINT

SET PRINT ESONE_SERV

PROCTAB

CLEAR DAQ_STATUS PROCTAB

PROMPT

SET VERBOSE PROMPT

PSHELL

PSHELL

RATE

SHOW RATE

READOUT

LOAD READOUT

REMOTE

REMOTE ACCESS
REMOTE RESET
REMOTE SHOW

REMOVE

REMOVE SEGMENTS

RESET

REMOTE RESET
RESET

RESTORE

RESTORE BASE

SEGMENTS

REMOVE SEGMENTS

SET

SET DISPATCHER
SET EVENT_SERV
SET FILEHEADER
SET FLUSHTIME
SET HISTOGRAM CHANNEL
SET HISTOGRAM TEXT

SET MAXCLIENTS ESONE_SERV
SET MAXCLIENTS EVENT_SERV
SET PRINT ESONE_SERV
SET STREAM_SERV
SET TASK
SET TRIG_MOD
SET VERBOSE DISPATCHER
SET VERBOSE ESONE_SERV
SET VERBOSE EVENT_SERV
SET VERBOSE GLOBAL
SET VERBOSE HISTOGRAM
SET VERBOSE PROMPT
SET XDISPLAY

SETUP

LOAD SETUP
SHOW SETUP

SHOW

REMOTE SHOW
SHOW ACQUISITION
SHOW BASE
SHOW COMMANDS
SHOW CVC_IRQ_MASK
SHOW DISPATCHER
SHOW ENVIRONMENT
SHOW ESONE_SERV
SHOW EVENT_SERV
SHOW HISTOGRAM
SHOW MESSAGE
SHOW ML_SETUP
SHOW RATE
SHOW SETUP
SHOW STATUS
SHOW STREAM_SERV
SHOW TAPE
SHOW TASK
SHOW TRIG_MOD

SHOW

SLAVE_READOUT

LOAD SLAVE_READOUT

START

START ACQUISITION

START EVENT_SERV

START MESSAGE

START TASK

STATUS

CLEAR DAQ_STATUS STATUS

SHOW STATUS

STOP

STOP ACQUISITION

STOP TASK

STREAM_SERV

SET STREAM_SERV

SHOW STREAM_SERV

TAPE

DISMOUNT TAPE

INITIALIZE TAPE

MOUNT TAPE

SHOW TAPE

TASK

SET TASK
SHOW TASK
START TASK
STOP TASK

TCP

DISABLE TCP
ENABLE TCP

TEXT

SET HISTOGRAM TEXT

TRIG_MOD

CLEAR TRIG_MOD
DISABLE TRIG_MOD
ENABLE TRIG_MOD
SET TRIG_MOD
SHOW TRIG_MOD

TYPE

TYPE EVENT

VERBOSE

SET VERBOSE DISPATCHER
SET VERBOSE ESONE_SERV
SET VERBOSE EVENT_SERV
SET VERBOSE GLOBAL
SET VERBOSE HISTOGRAM
SET VERBOSE PROMPT

VOID

VOID

XDISPLAY

SET XDISPLAY

XSHELL

XSHELL

Chapter 13

Command Summary

ATTACH BASE	name (m_histogram) Attaches existing histogram data base.
CAMAC CNAF	c n a f [d r]-LOG -NOPRINT (m_esone_serv) Executes local CAMAC cnaf.
CAMAC FILE	filenam -LOG -NOPRINT (m_esone_serv) Executes local CAMAC cnaf.
CLEAR DAQ_STATUS COUNTER	- (m_util) Clears status counters in the global daq status segment
CLEAR DAQ_STATUS PROCTAB	- (m_util) Clears daq process table in the global daq status segment
CLEAR DAQ_STATUS STATUS	- (m_util) Clears daq status bits in the global daq status segment
CLEAR HISTOGRAM	name (m_histogram) Clears histogram.
CLEAR PIPES	- (m_read_meb) Clears the subevent pipes (queue).
CLEAR TRIG_MOD	- (m_util) Resets the trigger module.
CLOSE FILE	[tape] (m_transport) Closes file.
CNAF	c n a f [d r] (m_camac) Executes local CAMAC cnaf.

COMMENT line -ERROR -INFO -COMMAND
 (m_dispatch) Writes line to log file.

CONNECT DISPATCHER [node]-ALL
 (m_prompt) Connects prompter to remote dispatcher.

CREATE BASE name histogram size
 (m_histogram) Creates histogram data base.

CREATE HISTOGRAM name dim type chan1 lo1 up1 [chan2 lo2 up2]
 (m_histogram) Creates histogram.

DEFINE COMMANDS task file -LOG
 (m_dispatch) Defines commands for task.

DELETE BASE name
 (m_histogram) Deletes histogram data base.

DELETE HISTOGRAM name
 (m_histogram) Deletes histogram.

DETACH BASE name
 (m_histogram) Detaches histogram data base.

DISABLE CVC_CAM_IRQ -
 (m_util) Disables CAMAC LAM and VSB interrupts

DISABLE EVENT_COPY -
 (m_collector) Disables event copy during data acquisition

DISABLE HISTOGRAM -
 (m_collector) Disables histogramming during data acquisition

DISABLE TCP -
 (m_transport) Disables tcp connection.

DISABLE TRIG_MOD -
 (m_util) Disables trigger module on trigger bus

DISCONNECT DISPATCHER [node]-ALL -KILL
 (m_prompt) Disconnects prompter from remote dispatcher.

DISMOUNT TAPE [tape]-UNLOAD
 (m_transport) Dismounts tape.

DUMP BASE base file
 (m_histogram) Dumps base into file.

DUMP HISTOGRAM name file -SEPARATE
(m_histogram) Dumps histogram in file or files.

ENABLE CVC_CAM_IRQ -
(m_util) Enables CAMAC LAM and VSB interrupts

ENABLE EVENT_COPY -
(m_collector) Enables event copy during data acquisition

ENABLE HISTOGRAM basename
(m_collector) Enables histogramming during data acquisition

ENABLE IRQ -
(m_util) Disables trigger module to send IRQ or LAM

ENABLE TCP -INCLUSIVE -EXCLUSIVE
(m_transport) Enables tcp connection.

ENABLE TRIG_MOD -
(m_util) Enables trigger module on trigger bus

HELP [k1 k2 k3 k4 k5 library]
(m_prompt) Outputs help information by keywords.

INITIALIZE TAPE label [tape]
(m_transport) Initializes tape.

LOAD ML_SETUP usf_file
(m_util) Loads setup file of multi-layer multi-branch daq system

LOAD READOUT usf_file
(m_read_meb) Loads readout table.

LOAD SETUP usf_file [crate_nr]
(m_util) Loads setup file.

LOAD SLAVE_READOUT usf_file
(m_read_cam_slav) Loads readout table.

MOUNT TAPE [tape]
(m_transport) Mounts tape.

NEWS [facility item path]-ALL
(m_dispatch) Outputs news.

OPEN FILE name [tape size number first inhead outhead]
-AUTO -PROMPT -EDIT -DISK
(m_transport) Opens file on tape.

SET STREAM_SERV [scale]-[NO]SYNC -[NO]KEEP -SCALED_KEEP -CLEAR
(m_stream_serv) Selects scaledown of streams.

SET TASK task pid -CLEAR
(m_dispatch) Sets task id.

SET TRIG_MOD -SLAVE
(m_util) Sets trigger module.

SET VERBOSE DISPATCHER -ON -OFF
(m_dispatch) Sets verbosity for dispatcher.

SET VERBOSE ESONE_SERV -ON -OFF
(m_esone_serv) Sets verbosity for Esone Server.

SET VERBOSE EVENT_SERV -ON -OFF
(m_event_serv) Sets verbosity for m_event_serv.

SET VERBOSE GLOBAL -ON -OFF -NEUTRAL
(m_util) Sets verbosity for all tasks

SET VERBOSE HISTOGRAM -ON -OFF
(m_histogram) Sets verbosity for m_histogram.

SET VERBOSE PROMPT -ON -OFF
(m_prompt) Sets verbosity for m_prompt.

SET XDISPLAY node
(m_prompt) Set name of remote display.

SHOW [node][task]-LOCAL -TASKS -DAQ -NET
(m_remote) Shows remote info. Executed by alias remote.

SHOW ACQUISITION [seconds]-SETUP -CRATES -SERVER -RATE -LOG
(m_util) Shows acquisition.

SHOW BASE [name]
(m_histogram) Shows information about histogram data base.

SHOW COMMANDS [task]-FULL -ALL
(m_dispatch) Shows known commands.

SHOW CVC_IRQ_MASK -
(m_util) Reads irq mask of the CVC irq controller

SHOW DISPATCHER [node]
(m_prompt) Shows connections to remote dispatchers.

SHOW ENVIRONMENT -
(m_dispatch) Shows environment parameters.

SHOW ESONE_SERV -FULL -LOG -CLIENT
(m_esone_serv) Shows status of m_esone_serv.

SHOW EVENT_SERV -FULL -LOG -CLIENT
(m_event_serv) Shows status of m_event_serv.

SHOW HISTOGRAM name -DATA -FULL
(m_histogram) Shows histogram info and content.

SHOW MESSAGE -
(m_dispatch) Shows status of internal message file.

SHOW ML_SETUP -
(m_util) Shows multilayer setup parameters

SHOW RATE [seconds]-OFF -ON
(m_util) Shows acquisition rate.

SHOW SETUP -
(m_util) Shows setup parameters

SHOW STATUS -
(m_util) Shows daqst parameters

SHOW STREAM_SERV -CLEAR
(m_stream_serv) Shows modes and counters.

SHOW TAPE [tape]
(m_transport) Shows tape information.

SHOW TASK [task]-FULL -ALL
(m_dispatch) Shows known tasks.

SHOW TRIG_MOD -
(m_util) Shows current setup of trigger module.

START ACQUISITION -
(m_util) Starts acquisition.

START EVENT_SERV [scale][events][maxclnt]
-[NO]PORTS -VERB
(m_event_serv) Starts m_event_serv.

START MESSAGE -
(m_dispatch) Starts the message logger.

START TASK task [file]
 (m_dispatch) Starts task.

STOP ACQUISITION -
 (m_util) Stops acquisition.

STOP TASK [task][pid]-ALL -KILL -ZOMBIE
 (m_dispatch) Stops task by sending command "exit"

TYPE EVENT [events id]-SAMPLE -VERBOSE
 (m_transport) Prints events.

VOID -
 (m_daq_rate) place holder, do not execute.

XSHELL command [a1 a2 a3 a4]
 (m_dispatch) Executes shell command line.

Chapter 14

Release Notes

14.1 General Changes

The new Multi-Branch System MBS V2 replaces the old Single-Branch System SBS V1. Although the functionality of the old SBS is integrated into MBS, there are some changes in the MBS compared to the old SBS.

14.2 New Features

The system has been enhanced into a multi-window system, which means that the subevent pipes of the reabout tasks can be located anywhere in memory as long as they are accessible by the collector in an address- mapped mode. This mechanism replaces the unflexible pipe setup of the SBS. It is now much easier to connect foreign systems. However, the base address of the pipes have to be specified individually in the setup file.

The most important change in functionality is the possibility to setup hierarchical structured (multi-layered) multi-branch systems. For this purpose a new multi-layer multi-branch setup parser facility has been created.

Also the functionality of the `m_collector` task has been enhanced substantially. It now acts as as a data dispatcher with various modes of operation in a multi-layer multi-branch system.

See chapter "Multi-Layer Multi-Branch Systems" for further information (7, page 65).

14.3 Directory Structure

The new Multi-Branch System MBS is located under the top directory `/mbs`. The structure is the same as the one below the old `/sbs`. The environment variable `SBSROOT` has been replaced by `MBSROOT`.

14.4 Log file

The log file name is now `mbslog.1` instead of `sbslog.1`.

14.5 Setup File (setup.usf)

The specification file (`setup.usf`) structure for a single-crate or single-branch system has been changed dramatically. This was necessary to support multi-windows, multi-branches and multi-layers. See the description in the section Single-Crate and Single-Branch Setup Specification.

14.6 Readout

14.7 Changes for MBS like Readout

The change visible for users is the parameter `set` passed to the user `init` and `readout` function. See the new structure in the section User Readout Function (6, page 47).

14.8 Internal Changes

The program `m_read_cam_slave.c` has been renamed to `m_read_cam_slav.c` to be consistent with the task name.

14.9 Environment

The MBS consists of several environments. One usually is local, the others are remote. To control a distributed environment one uses the prompter. The nodes of the environment must be written in a text file `node_list.txt`, one per line. The prompter reads this file on the current path and starts/connects dispatchers and message logger clients on these nodes. On the local node (which must be included in this file), the message logger server is started. Because the prompter uses `rsh` commands, one must provide a file `.rhosts` on the home path specifying "trusted hosts". The file looks like:

```
trustedhost trusteduser
CVC40.gsi.de  root
e7_1.gsi.de  root
```

The target node reads this file and checks if a request from a remote node is allowed.

14.9.1 Default Path

When a dispatcher is started directly by `mbs`, the default path is the same as current `PWD`. When tasks are started by this dispatcher, the default path of these tasks is the same.

When a dispatcher is started by the prompter, however, the default path of this dispatcher and all its tasks is the `HOME` path of the user.

When the message logger is started by interactive dispatcher, the log file will be located on `PWD`. The same is true when the message server is started by the prompter.

14.9.2 Relative Path Specifications (NOT YET IMPLEMENTED)

Optionally, one may set the environment variable `MBSHOME` to an arbitrary path. Then this path will be the default path of all tasks, except the message logger which still uses `PWD` for the log file. All file references (setup files, readout files, command procedures) may then reference `MBSHOME` by `DOT`, i.e. `./Mydir/abc`. Note that independent of `PWD` the prompter uses `MBSHOME` as default path.

14.10 Command Interface Syntax

Command qualifiers (switches) are now preceded by a hyphen instead of a slash, i.e. SBS command `set verb /on` would in MBS be `set verb -on`. The advantage is that path specifications containing slashes no longer need to be enclosed in `""`. In addition, strings beginning with a slash are not lower cased any longer. Thus, a command `load setup "/Mydir/setup"` can be written as `load setup /Mydir/setup`.

14.11 Distributed Environment (Prompter)

The next important new feature is that remote dispatchers can be controlled from one central prompter. The prompter is a new program invoked by `prm`. It starts a local message server and dispatchers and message clients on remote nodes found in `node_list.txt`. Then commands can be sent by the prompter to one or all remote dispatchers. The output of all remote tasks is sent to the message server and printed on the terminal. Thus a multinode environment can be controlled from one terminal.

Prompter and message server will be available soon on AIX, DECunix, and eventually on OpenVMS.

14.11.1 Remote Commands

The prompter optionally may receive input from a remote node. There is a routine `f_pr_send` to send a command line to such a prompter via TCP. Using this routine remote programs may execute commands in the MBS. No information except the command completion status is returned

back. Text output of the command will go to the prompter's (message server's) terminal. The prompter must be started by

```
prm -r nodelist
```

where `nodelist` is a list of nodes which are allowed to connect and send commands. By command `REMOTE ACCESS` this list may be modified after the prompter is started. The prompter accepts input from terminal and TCP, if enabled.

14.11.2 Remote Tasks

When a remote task terminates, the remote dispatcher removes it automatically from the task list. The new message:

```
... :dispatch :-I- f_stc read interrupted, recover tasks.  
... :dispatch :Task xxx ID x removed!
```

indicates that a task terminated.

14.12 Obsolete Commands

14.12.1 SET MAXCLIENTS EVENT_SERV

Function is now in command `SET EVENT_SERV`.

14.12.2 SET STREAM

Function is now in commands `SET EVENT_SERV` (for event server) and `SET STREAM_SERV` (for stream server).

14.12.3 SET MAXCLIENTS EVENT_SERV

Function is now in command `SET EVENT_SERV`.

14.13 Changed Commands

14.13.1 Start Dispatcher

To make clear that one is using MBS instead of SBS, the dispatcher is now invoked by `mbs` and answers with `mbs>`. The functionality of the dispatcher is almost the same as in SBS.

14.13.2 START EVENT_SERV

The command

```
START EVENT_SERV [stream] [events] [maxclnt] -NOPTS -VERB
```

has been changed to

```
START EVENT_SERV [scale] [events] [maxclnt] -[NO]PTS -VERB
  scale      : scaledown streams to analyse.
              Def.=1: take all
  events     : maximum number of events to copy from a stream.
              Def.=-1: take all
  maxclnt    : maximum number of clients.
              Def.=3
  -VERB      : Verbose mode.
```

The `-NOPTS` option is now default. The first argument has been renamed from `stream` to `scale`.

14.13.3 ENABLE HISTOGRAM

The qualifier `-EVENTCOPY` is obsolete. There are two new commands `ENABLE/DISABLE EVENT_COPY`.

14.13.4 ENABLE TCP

The qualifier `-INCLUSIVE` is now default. There is a new qualifier `-EXCLUSIVE`.

14.13.5 START TASK

The path of a task can now be specified together with the program:

SBS (old):

```
SBS> START TASK m_read_meb "/Mydir/m_read_meb"
```

MBS (new):

```
MBS> START TASK /Mydir/m_read_meb
```

Note that the quotes are no longer needed.

14.13.6 STOP TASK

This command now has new qualifiers for a better task control:

```
STOP TASK [task] [pid] -ALL -KILL -ZOMBIE
  task  : Task (program) name
  pid   : Optional pid used with -KILL if task not known.
  -ALL  : Stop all known tasks except message logger.
  -KILL : Stop task by calling kill function with
          signal SIGTERM.
  -ZOMBIE : Remove status blocks of terminated tasks
            to let them die (Z to RIP).
```

14.14 New Commands

14.14.1 REMOTE ACCESS

This command sets the list of nodes which are allowed to send commands to a prompter.

```
prompt> REMOTE ACCESS [node list]
```

If no node list is specified, no more command clients can connect.

14.14.2 REMOTE SHOW

Besides the new commands of the prompter to control remote dispatchers there are two new commands to get information of remote nodes and to cleanup remote nodes.

```
prompt> REMOTE SHOW -ALL [-TASKS] [-DAQ] [-NET]
prompt> REMOTE SHOW -LOCAL
prompt> REMOTE SHOW <node>
```

The commands are also available from the shell:

```
() remote SHOW @file
() remote SHOW -LOCAL
() remote SHOW <node>
```

The `-all` qualifier in the prompter command corresponds to `@file` in the shell command.

14.14.3 REMOTE RESET

This command cleans up remote (and/or) local nodes, i.e. kills all MBS tasks, creates new message files and clears the status segment `daqst`.

```
prompt> REMOTE RESET -ALL
prompt> REMOTE RESET -LOCAL
prompt> REMOTE RESET <node>
```

The commands are also available from the shell:

```
() remote RESET @file
() remote RESET -LOCAL
() remote RESET <node>
```

The `-all` qualifier in the prompter command corresponds to `@file` in the shell command.

14.14.4 SET EVENT_SERV

This command replaces the `SET STREAM` and `SET EVENTS` commands:

```
SET EVENT_SERV [scale] [events] [maxclnt] -ALL
  scale      : scaledown streams to analyse. 1: take all
  events     : maximum number of events to copy from a stream
  maxclnt    : maximum number of clients
  -ALL       : take all events per selected stream
```

14.14.5 SET STREAM_SERV

This command replaces the `SET STREAM` command:

```
SET STREAM_SERV [scale] -[NO]SYNC -[NO]KEEP -SCALED_KEEP -CLEAR
  scale      : scaledown streams to analyse. 1: take all
  -[NO]SYNC  : synchronous mode: send all scaled, wait for request.
  -[NO]KEEP  : Keep streams when scale=1 and when there are > 3
               free streams.
  -SCALED_KEEP : Keep scaled down streams when there are > 3 free streams.
  -CLEAR     : Clear counters.
```

14.14.6 ENABLE/DISABLE EVENT_COPY

This command replaces the `-EVENTCOPY` qualifier of the `ENABLE HISTOGRAM` command.

14.14.7 ENABLE/DISABLE IRQ

14.14.8 ENABLE/DISABLE TRIG_MOD

14.14.9 LOAD ML_SETUP

14.15 Stream Server

There is a new version of the MBS stream server. It provides several operation modes for best performance in different setups. In all modes the scale factor controls the DAQ performance.

The default mode after startup is same as by following command:

```
mbs> set stream_server scale=2 -NOSYNC -NOKEEP
```

This means, every 2nd stream is delivered to a client, if a request was there.

14.15.1 Synchronous Mode

The new synchronized mode is enabled by switch `-SYNC`:

```
mbs> set stream_server scale=n -SYNC
```

This means, for every nth stream the server waits for the clients request. With n=1 the client gets all streams and acquisition speed is defined by client.

14.15.2 Asynchronous Modes

In `-NOSYNC` mode there are two flavors of the `-KEEP` mode:

Conditional Keep

```
mbs> set stream_server scale=n -KEEP
```

When n=1 the server keeps a stream as long as there are more than 3 free streams available. The effect is that during spill pauses the client will get as many streams as he requests (if there are any), but the acquisition speed may slow down especially at high event rates but low data rates. With n>1 keeping is switched off and the mode is like `-NOKEEP`.

Scaled Keep

```
mbs> set stream_server scale=n -SCALE
```

The server keeps every *n*th stream as long as there are more than 3 free streams available. The effect is that during spill pauses the client will get streams on request, but maybe not as many as in `-KEEP` mode. On the other hand in `-SCALE` mode the impact on the acquisition speed can be controlled. With *n*=1 this mode is the same as `-KEEP`.

The `show` command has been enhanced and displays the mode and counters. The counters are only incremented if a client is connected. See `HELP SET STREAM_SERV` and `HELP SHOW STREAM_SERV`.

One should play with the modes to get the best compromise of DAQ performance and data transfer for monitoring.

14.16 Transport Server

When a client (GOOSY Transport Manager) connects to the MBS Transport Server, the server first sends four longwords with information about buffer sizes and streams:

1. Endian longword, must be 1
2. Buffer size [bytes]
3. Buffers per stream
4. Number of streams

This is the same information as the stream server sends after accepting a client. The GOOSY Transport Manager checks if the buffer parameters conform to its own ones and disconnects if not.

Note: The buffer size can be specified in GOOSY TMR by command

```
INIT ACQ /TCP size=xxx
```

But this command can only be executed once! Therefore the TMR must be restarted in order to change the buffer sizes.

14.17 Help

The `help` command has been enhanced. The path with the help files can be optionally specified by environment variable `HELPPDIR`. Otherwise the MBS default `MBSROOT/lib` is used. Typing `help` without arguments lists the available help libraries. A specific help library can be selected.

```
CVC38 goofy (43) help -mbs
***** Help library -mbs          **** file /mbs/prod/lib/mbs.hlp:
attach          camac              clear          close
cnaf            connect            create         define
delete         detach              disable        disconnect
dismount       dump                enable         help
```

initialize	load	mount	news
open	remove	restore	set
show	start	stop	type
xshell			

When no library is specified, all libraries are searched for keywords:

```
CVC38 goofy (44) help attach
***** Help library -goosy      **** file /mbs/prod/lib/goosy.hlp:
***** Help library -mbs        **** file /mbs/prod/lib/mbs.hlp:
attach
->base
```

Chapter 15

Glossary

GMC_MBS_GLOSS

AEB: Aleph Event Builder, a Fastbus controller with an 68020 processor running OS/9.

Branch: Logically a branch is a set of pipes read from one collector. Physically a set of memories addressable from one master.

CAV: CAMAC VSB Controller. GSI-developed CAMAC board mapping CAMAC to VSB.

CBV: Enhanced version of CAV.

Copy-filter: Parameter set specified by event clients to receive only parts of events. See also **Event-filter** and **Filter-set**.

CVC: CAMAC VSB Computer. GSI-developed CAMAC board with 68030 processor and fast memory mapped CAMAC access. Can be used also as crate controller. Runs pSOS and Lynx.

EBI: GSI-developed AEB to VSB interface.

Event-filter: Parameter set specified by event clients to receive only certain events. See also **Copy-filter** and **Filter-set**.

Environment: Set of all tasks controlled by one dispatcher. Several environments on several nodes can be controlled from one prompter.

FIFA: GSI-developed SMI to VSB interface.

Filter-set: Complete parameter set specified by event clients to receive only parts of certain events. See also **Copy-filter** and **Event-filter**.

Master: Similar to slave used in different context.

1. *Hardware:* Masters can read/write to remote memory, i.e. there are VSB and VME masters, sometimes called *branch masters*.
2. *Software:* Readout masters fill one pipe in local memory. One master readout task is running on one processor (branch master) together with at least a collector.
3. *Trigger:* One trigger module must be master. It is the one getting the trigger signals from the experiment.

Pipe: Piece of memory where readout tasks or multi-layer collectors write subevents and a collector reads them. Synchronization is done through the pipe.

Profile: An ASCII file where named parameters and values are stored. Profiles are read by programs to get these values, i.e. setup files and readout files.

Readout: There are two versions of readout tasks: Master and Slave. These names do **not** imply a relation between them. The master version runs on the branch master, where the collector runs. The slave version runs alone. Therefore the slave polls for triggers, whereas the master waits for an interrupt. Optionally the master can also be set up to poll.

Segment: A segment in Lynx is a contiguous array in virtual memory. When created by `smem_create`, it is mapped to a physical address range which is contiguous. When created by `smem_get` it is contiguous in virtual memory, but may cover several noncontiguous physical memory locations.

SFI: Struck Fastbus controller with a VME create builtin providing two VME slots.

Slave: Used in different contexts.

1. *Hardware:* Slaves cannot write to remote memory. I.e. there are VSB and VME slaves.
2. *Software:* Readout slaves fill one pipe. Only one task, the slave readout, is running on one processor. When the processor is bus master, the pipe can be located in remote memory.
3. *Trigger:* All trigger modules except one master are slaves. They get the trigger signal from the master trigger via trigger bus.

Stream: A set of buffers. Events do not span between streams. One stream is either free, locked by the collector, locked by the transport, or locked by stream or event server.

VME: Versa Module Enhanced bus.

VSB: VME Subsystem Bus. Differential version developed at GSI to connect CAMAC and Fastbus crates with VME modules.

Window: The address space where a collector can access pipes, i.e. a VME processor sees all pipes of a VSB branch in one address window. Multiwindow means that the addresses of pipes can be specified quite freely.

Index

A

Acquisition
 control 33
 output 34
Analysis 12, 92
 histogram 36, 107, 112
 on-line 36, 92

B

Buffer 80
 element 79
 data 79, 80
 header 79, 80
 element header 81
 file header 80
 files 80
 format 79, 80, 82
 structure 80
Byte order 79

C

CAMAC 12, 30, 31
 Esone 35, 117
 Readout 11, 30, 31, 56, 62
Cleanup 39
Client
 analysis 12
 Event Server 92
 GOOSY 92
 Histogram 116
 listmode 11
cmd 7, 21
CNAF 35
Collector 11

Command 12
 argument 23
 control 33
 default 23
 definition 28, 84
 dispatcher 21
 example 27
 file 23
 help 23
 interface 7, 21
 line 21
 procedure 23
 qualifier 23
 Remote 10
 user 28

Components 9, 10

Connect 92

Control
 commands 33
 structure
 initialize 12

Conventions 14

CVC 18

D

Data
 rate 12
Defaults 23
Dispatcher 10
 commands 21

E

Endian 79
Environment 9, 21

- remote 25
- startup 31, 32
- variables 14

Error

- recovery 39

Esone 35

- library 35, 117
- Server 12
- windows 35

Event 79, 82, 83

- filter 12, 101
- format 83
- server 12
- spanning 82
- types 84

Examples 41

F

File

- header 34, 80
- name 14, 34
- output 34

Filter

- event 12, 101

Formats

- buffer 79, 80, 81, 82
- event 83

G

GOOSY 92

- Analysis 12, 92
- Esone 35
- Transport Manager 11, 12, 34, 92

H

Hardware 17, 18

Header 34

Help 8, 12

Histogram 12, 36, 107

- access 114
- analysis 107, 112
- client 116

- commands 111
- disable 112
- enable 112
- functions 115
- manager 107, 108
- server 108, 116

I

Information 8

Interrupt

- handler 29

L

Log file 24

Log-file 10

Login

- procedure 29
- shell 29

M

Magtape 33

- dismount 33
- end of tape 34
- mount 33

Message 12

- logger 10

Monitor 12

Monitoring

- on-line 36, 92

Motif 27

mrf

- CAMAC readout table 30

msg_new 12

msg_sho 12

Multi-Branch

- setup
 - definition 76
 - description 67

m_collector 11

m_dispatch 10

m_esone_serv 12

m_event_serv 12

m_histogram 12
m_msg_log 10
m_prompt 10
m_stream_serv 12
m_transport 11
m_util 12

N

Names 14
Net 11
netstat 38
News 8, 12

O

Output 34

P

pdf
 parser definition file 15, 30, 73
Performance 19
Pipes
 subevent 48
Port numbers 38
Profiles 15, 30
 readout 77
 setup
 definition 74, 76
Prompter 10, 25
 commands 25

R

Readout 11, 30, 62
 AEB 63
 FASTBUS 61
 function 31, 57, 62
 macro 59
 mechanism 30, 55, 62
 table 30, 48, 56, 77
 tasks 47
Remote 12, 39
 Commands 10
 Environment 25
Reset 39

Remote 12

S

Server
 Esone 12
 Event 89
 Remote 89
 Histogram 108, 116
 restart 38
 Stream 12, 87, 92
 Transport 88, 92
Setup 30
 description 67
 files 15, 30, 49
 definition 74, 76
 description 50
Shell 29
 commands 12
Show
 Remote 12
Single Branch
 setup
 definition 74
 description 50
Sockets 38
Software
 versions 13
Sources 14
Start
 acquisition 33
 MBS 30
Startup 29
Status 12
 task 38
Stop
 acquisition 33
Stream 82
 Server 12, 87
Subevent
 format 83
 pipes 48

T

Table 30

Tape 11, 33, 34
 dismount 33
 end of tape 34
 error 34
 mount 33

Task 9, 10
 states 38
 table 38

TCP 11, 38

Transport 11, 34, 88

Trigger 18, 30

Types
 event 84

U

usf
 user setup file 15, 30, 50, 67
Utility 12

V

Versions 13

W

Write
 tape 34

Z

zombie 38

Contents

1	Preface	3
1.1	Intended Readers	4
1.1.1	New Users of MBS	4
1.1.2	Experienced Users of SBS	4
1.1.3	Optional Facilities	4
1.1.4	Reference Chapters	4
1.1.5	List of all Chapters	5
1.2	Other Manuals	5
1.2.1	GSI Multi-Branch System Reference Manual	5
1.3	MBS Authors and Advisory Service	6
2	Overview	7
2.1	Summary	7
2.2	Command Interface	7
2.3	Help	8
2.4	News	8
2.5	MBS Environment	9
2.5.1	Command Dispatcher	10
2.5.2	Message Logger	10
2.5.3	Prompter	10
2.5.4	Readout	11
2.5.5	Collector	11
2.5.6	Transport	11
2.5.7	Event Server	12
2.5.8	Stream Server	12
2.5.9	Esome Server	12
2.5.10	Histogram Manager	12
2.5.11	Utility	12
2.6	Standalone Programs	12
2.7	Software Organisation	13
2.7.1	File Organisation	13

	Production and Development	13
	Directories	14
2.7.2	Naming Conventions	14
	File Names	14
	Environment Variables	14
2.7.3	Profile Interface	15
3	Hardware	17
3.1	Single-Branch Systems	17
3.2	Single-Branch Hardware Setup Examples	18
3.2.1	One VSB Branch	18
3.2.2	One VME Branch	19
3.3	Performance Measurements	19
4	Command Interface	21
4.1	Local Environment	21
4.2	Line Input	21
4.3	Arguments and Qualifiers	23
4.4	Command Procedures	23
4.5	Defaults	23
4.6	Log File	24
4.7	Remote Environment	25
4.7.1	Prompter	25
4.7.2	Additional Prompter Features	25
4.8	Motif Interface	27
4.9	Command Example	27
4.10	User Defined Commands	28
5	Running a Data Acquisition	29
5.1	Prerequisites for MBS	29
5.1.1	Account	29
5.1.2	Login Procedure	29
5.2	Starting MBS	30
5.2.1	Steps	30
5.2.2	Setup	30
5.2.3	Readout	30
	CAMAC Readout Profile	30
	Readout by Function	31
5.2.4	Start Single Environment	31
5.2.5	Start Remote Environments	32
5.3	Controlling MBS	33
5.3.1	Acquisition	33

Tape Handling	33
End of Tape	34
Tape Errors	34
5.3.2 File Output	34
File Header	34
File Names	34
5.3.3 CAMAC Esone Calls	35
5.4 On-line Analysis	36
5.4.1 MBS Histogramming	36
5.4.2 Data Channels from MBS	36
GOOSY without Filters	37
GOOSY and PAW without Filters	37
Using the Event Servers	37
GOOSY and PAW with Filters	37
Any Program without Filters	37
5.5 Error Recovery	38
5.5.1 Task States	38
5.5.2 MBS Task Table	38
5.5.3 Hanging TCP Sockets	38
5.5.4 Recovery	39
5.6 Session Example	41
5.6.1 Single CAMAC System	41
6 Readout Control	47
6.1 Readout Tasks	47
6.2 Readout Software Overview	48
6.3 Single-Branch Setup Specification	49
6.3.1 Setup File: Parameters	50
6.4 Readout Specification	55
6.5 Table Readout	56
6.5.1 Table Readout Parameters	56
6.5.2 Table Readout Subevents	56
6.5.3 Table Readout Example	56
6.6 User Function Readout	57
6.6.1 Macro Readout Method	59
6.6.2 Static Pointer Readout Method	60
6.6.3 Changing Subevent Headers	60
6.6.4 User Readout Functions on AEB-EBI under OS-9	61
6.7 Running a System with User Readout Functions	62
6.7.1 Running a Single Processor System	62
6.7.2 Running a System with Slave Processors	62
6.7.3 Running a System with AEB Slave Processors	63

7	Multi-Layer Multi-Branch Systems	65
7.1	Introduction	65
7.2	Multi-Layer Multi-Branch Setup Specification	67
7.2.1	Setup File: Parameters	67
7.3	Example: Multi-Branch Setup	69
7.4	Example: Multi-Layer Multi-Branch Setup	70
8	Data Structures	73
8.1	Profile Definitions	73
8.1.1	Single-Branch Setup File	74
8.1.2	Multi-Branch Setup File	76
8.1.3	Readout Tables	77
8.2	List Mode Data Structures	79
8.2.1	Glossary	79
8.2.2	Byte Order	79
8.2.3	Buffers	80
8.2.4	Buffer Files	80
8.2.5	GSI File Header Buffer	80
8.2.6	GSI Buffer Element Header	81
8.2.7	GSI Buffer	82
	Event Spanning	82
8.2.8	Streams and Buffers	82
8.2.9	Event Structures	83
	Event	83
	Subevent	83
8.2.10	Types and Subtypes	84
	Type Numbers	84
	Subtype Numbers	84
	Buffer	84
	Event	84
	Subevent	84
8.3	Command Definition File	84
9	Event Serving and Filtering	87
9.1	Stream Server	87
9.1.1	Synchronous Mode	87
9.1.2	Asynchronous Modes	87
	Conditional Keep	87
	Scaled Keep	88
9.2	Transport Server	88
9.3	Event Server	89
9.4	Remote Event Server	89

9.4.1	Parameters	89
9.4.2	Tuning	90
9.5	GOOSY On-line Analysis	92
9.5.1	GOOSY Transport Manager	92
	Connection to MBS Transport	92
	Connection to MBS Stream Server	92
	Disconnect	92
9.5.2	GOOSY Analysis	92
9.6	PAW On-line Analysis	93
9.7	PAW Clients on VMS	93
9.7.1	PAW as Client for the Event Server in VMS	94
9.7.2	Using VMS Global Sections with PAW	95
9.8	PAW Clients on AIX	96
9.8.1	PAW as Client for the Event Server in AIX	97
9.8.2	Writing to Shared Memory outside PAW	98
9.8.3	Accessing Shared Memory with PAW	98
9.9	Argument Description for Event Clients	99
9.9.1	Function	99
9.9.2	Arguments	99
9.9.3	Example	100
9.10	Filters	101
9.10.1	Copy-Filter	101
9.10.2	Event-Filter	102
	Description	102
	Filter Subset Specification	102
9.10.3	Filter Examples	103
	Simple Event-Filter	103
	Complex Event-Filter	104
	Copy- and Event-Filter	104
9.11	General Purpose Event I/O Library	106
10	Histogramming	107
10.1	Introduction	107
10.1.1	Histogram Manager	107
10.1.2	Analysis Template	107
10.1.3	Histogram Server	108
10.2	Histogram Manager	108
10.2.1	General Description	108
10.2.2	Histogram Command Overview	111
10.3	Histogramming	112
10.3.1	General Description	112
10.3.2	Enabling and Disabling Histogramming	112

10.3.3	f_his_anal: Event Access and Return Status	114
10.4	Histogramming Functions	115
10.5	Histogram Server	116
10.6	Histogram Client Library	116
11	ESONE Library	117
11.1	Esome Clients	117
12	Keyword Summary	121
MBS_keywords	122
13	Command Summary	135
14	Release Notes	143
14.1	General Changes	143
14.2	New Features	143
14.3	Directory Structure	143
14.4	Log file	144
14.5	Setup File (setup.usf)	144
14.6	Readout	144
14.7	Changes for MBS like Readout	144
14.8	Internal Changes	144
14.9	Environment	144
14.9.1	Default Path	145
14.9.2	Relative Path Specifications (NOT YET IMPLEMENTED)	145
14.10	Command Interface Syntax	145
14.11	Distributed Environment (Prompter)	145
14.11.1	Remote Commands	145
14.11.2	Remote Tasks	146
14.12	Obsolete Commands	146
14.12.1	SET MAXCLIENTS EVENT_SERV	146
14.12.2	SET STREAM	146
14.12.3	SET MAXCLIENTS EVENT_SERV	146
14.13	Changed Commands	146
14.13.1	Start Dispatcher	146
14.13.2	START EVENT_SERV	147
14.13.3	ENABLE HISTOGRAM	147
14.13.4	ENABLE TCP	147
14.13.5	START TASK	147
14.13.6	STOP TASK	148
14.14	New Commands	148
14.14.1	REMOTE ACCESS	148

14.14.2	REMOTE SHOW	148
14.14.3	REMOTE RESET	148
14.14.4	SET EVENT_SERV	149
14.14.5	SET STREAM_SERV	149
14.14.6	ENABLE/DISABLE EVENT_COPY	149
14.14.7	ENABLE/DISABLE IRQ	150
14.14.8	ENABLE/DISABLE TRIG_MOD	150
14.14.9	LOAD ML_SETUP	150
14.15	Stream Server	150
14.15.1	Synchronous Mode	150
14.15.2	Asynchronous Modes	150
	Conditional Keep	150
	Scaled Keep	150
14.16	Transport Server	151
14.17	Help	151
15	Glossary	153
	Index	155